

The Transition  
Accelerator



L'Accélérateur  
de transition

TRANSITION ACCELERATOR REPORTS  
Volume 2 • Issue 3 • September 2020

# TOWARDS NET-ZERO ENERGY SYSTEMS IN CANADA: A KEY ROLE FOR HYDROGEN

David B Layzell PhD, FRSC  
Cameron Young PEng, MSc  
Jessica Lof MSc  
Jonathan Leary  
Song Sit PEng, PhD

*A Transition Accelerator 'White Paper'*



# Towards Net-Zero Energy Systems in Canada: *A Key Role for Hydrogen*

**David B Layzell PhD, FRSC**

Research Director, The Transition Accelerator

Professor and Director, Canadian Energy Systems Analysis Research (CESAR), University of Calgary

**Cameron Young PEng, MSc**

Energy Systems Analyst, CESAR, University of Calgary

**Jessica Lof MSc**

Research Lead on Freight Transport, CESAR, University of Calgary

**Jonathan Leary**

Summer Research Assistant, CESAR, University of Calgary

**Song Sit PEng, PhD**

Senior Associate, CESAR, University of Calgary



UNIVERSITY OF  
CALGARY

**CESAR**  
CANADIAN  
ENERGY SYSTEMS  
ANALYSIS RESEARCH

**Contact:**

Dr. David B. Layzell,

Tel: 403 220-5161

Email: [dlayzell@ucalgary.ca](mailto:dlayzell@ucalgary.ca)

Web: [www.transitionaccelerator.ca](http://www.transitionaccelerator.ca)

Citation:

Layzell DB, Young C, Lof J, Leary J and Sit S. 2020. Towards Net-Zero Energy Systems in Canada: A Key Role for Hydrogen. **Transition Accelerator Reports**: Vol 2, Issue 3. <https://transitionaccelerator.ca/towards-net-zero-energy-systems-in-canada-a-key-role-for-hydrogen>



# Preface

This white paper was prepared by [The Transition Accelerator](#) to provide techno-economic and environmental details, as well as a pan-Canadian perspective for the work of 'Alberta's Industrial Heartland Hydrogen Task Force' in assessing the ability of the Alberta Industrial Heartland region to contribute to the transition to a net-zero energy future. The Task Force report (to be released in Fall 2020) and this study are provided to inform decision makers in industry and government regarding the nature of a future, net-zero energy system and the important role for hydrogen in the energy transition.

The Transition Accelerator is a pan-Canadian, non-profit organization that works with groups across the country to solve business and social challenges while building emissions reductions into solutions. The Accelerator philosophy starts with understanding that we live in a time of disruptive change which is shaping the future. The Accelerator harnesses disruptions, shaping the future by helping develop credible and compelling transition pathways and actively taking steps down these pathways to positive future states.

The Accelerator uses a four-stage methodology:

1. **Understand** the system that is being transformed, including its strengths and weaknesses, and the technology, business model, and social innovations that are poised to disrupt the existing system by addressing one or more of its shortcomings.
2. **Codevelop** transformative visions and pathways in concert with key stakeholders and innovators drawn from industry, government, indigenous communities, academia, and other groups. This engagement process is informed by the insights gained in Stage 1.
3. **Analyze** and model the candidate pathways from Stage 2 to assess costs, benefits, trade-offs, public acceptability, barriers and bottlenecks. With these insights, the process then re-engages key players to revise the vision and pathway(s) so they are more credible, compelling and capable of achieving societal objectives.
4. **Advance** the most credible, compelling and capable transition pathways by informing innovation strategies, engaging partners and helping to launch consortia to take tangible steps along defined transition pathways.



# Acknowledgements

The Transition Accelerator is highly appreciative of its funding sponsors (see logos below) and the Mayors of the five municipalities making up the Alberta Industrial Heartland. Without their support and encouragement, this work would not be possible. The next page identifies the names of the individuals who provided valuable data and expertise as well as critical insights and perspectives to The Transition Accelerator's analytical team as the work progressed. We also appreciate the support of Dr. Lina Kattan (Professor of Civil Engineering at the University of Calgary) and the Integrated Infrastructure for Sustainable Cities (IISC) NSERC CREATE program for the funding support for Jonathan Leary to work on the project over the summer of 2020.

## Partners in the Alberta Industrial Heartland Project



CITY OF  
FORT SASKATCHEWAN  
ALBERTA



## Transition Accelerator Sponsors

IVEY foundation



McConnell

THE BOREALIS  
FOUNDATION



CTFF Chisholm Thomson  
Family Foundation

THE W. GARFIELD WESTON  
FOUNDATION



# Participants in the Alberta Industrial Heartland Hydrogen Task Force

## Task Force Leaders

- **Mayor Alanna Hnatiw**, Sturgeon Country
- **Mayor Don Iveson**, City of Edmonton
- **Mayor Gale Katchur**, City of Fort Saskatchewan
- **Mayor Rod Frank**, Strathcona County
- **Reeve David Diduck**, Lamont County

## Analytical Team and Report Authors

- **David Layzell**, Research Director, The Transition Accelerator
- **Cameron Young**, Energy Systems Analyst, CESAR
- **Jessica Lof**, Research Lead Freight, CESAR
- **Jonathan Leary**, Research Assistant, CESAR
- **Song Sit**, Senior Associate, CESAR

## Special Advisors to the Analytical Team

- **Hilary Faulkner**, Director, Strategic Policy and Energy Diversification, Alberta Energy
- **Oleg Podporin**, Senior Policy Analyst, Natural Gas Strategy and Engagement, Alberta Energy
- **Wes Lu**, Senior Analyst, Alberta Energy

## Task Force Advisors

- **Mark Summers**, Executive Director, Technology and Innovation at Emissions Reduction Alberta (ERA)
- **Justin Riemer**, Assistant Deputy Minister, Western Economic Diversification Canada, Alberta Region, Government of Canada
- **Mark Kirby**, President and CEO, Canadian Hydrogen and Fuel Cell Association
- **Barbra Korol**, Executive Director, Strategic Policy Branch, Alberta Department of Energy
- **Chris Nash**, President, Alberta Motor Transport Association
- **Sean McCoy**, Assistant Professor, Department of Chemical and Petroleum Engineering, University of Calgary
- **Jim Lothrop**, Director General, Innovation Centre, Transport Canada
- **Michele Evans**, Assistant Deputy Minister, Tourism and Economic Development, Government of Alberta
- **John Zhou**, Vice-President, Clean Energy, Alberta Innovates
- **Helen Ryan**, Assistant Deputy Minister, Environment and Climate Change Canada
- **Robert Hamaliuk**, Executive Director, Climate Change Policy, Government of Alberta
- **Paul Cheliak**, Vice-President, Government and Regulatory Affairs, Canadian Gas Association
- **Bob Koch**, Professor, Faculty of Engineering, University of Alberta
- **Margaret Bateman**, Senior Consultant, ZGM Marketing
- **Mollie Johnson**, Assistant Deputy Minister, Natural Resources Canada

# Copyright Information

**DISTRIBUTION:** Transition Accelerator Reports are available online at [www.transitionaccelerator.ca](http://www.transitionaccelerator.ca).

**DISCLAIMER:** The opinions expressed in this publication are the authors' alone.

**COPYRIGHT:** Copyright © 2020 by The Transition Accelerator. All rights reserved. No part of this publication may be reproduced in any manner whatsoever without written permission except in the case of brief passages that may be quoted in critical articles and reviews.

**ISSN:** Transition Accelerator Reports (Online format): ISSN 2562-6264

**MEDIA INQUIRIES AND INFORMATION:** For media inquiries, please contact [dlayzell@transitionaccelerator.ca](mailto:dlayzell@transitionaccelerator.ca)

**PLACE OF PUBLICATION:** The Transition Accelerator, Calgary, AB

**VERSION:** 2



# TOWARDS NET-ZERO ENERGY SYSTEMS IN CANADA: *A KEY ROLE FOR HYDROGEN*

## Table of Contents

	<u>Page</u>
Executive Summary	8
1. Introduction	13
2. The Cost of Low Carbon Hydrogen Production in Canada	20
3. Emissions Intensity and Life-Cycle Implications for Hydrogen	30
4. The Magnitude of the Opportunity	41
5. Summary and Conclusions	49



The Transition  
Accelerator



L'Accélérateur  
de transition

**TOWARDS NET-ZERO ENERGY SYSTEMS IN CANADA:  
*A KEY ROLE FOR HYDROGEN***

Executive Summary





# Executive Summary

## **The Net-Zero Emissions Challenge.**

Canada and 72 other nations of the world have committed to [net-zero greenhouse gas \(GHG\) emissions by 2050](#). Since half of Canada's GHG emissions are associated with the end-use combustion of fuels like gasoline, diesel, natural gas and kerosene (jet fuel), achieving the net-zero target will require the replacement of these carbon-based fuels with energy carriers that produce no emissions at end use.

Electricity made from very low or zero-emission sources will play a significant role, requiring a two to three-fold increase in generation and use over the next 30 years. However, direct electrification of sectors such as heavy freight (road and rail), off-road vehicles, shipping, planes, space heating in cold climates, and heavy industries (e.g. steelmaking) is not feasible from a logistical or economic perspective. For such markets, zero-emission fuels are required, and hydrogen is internationally recognized as a fuel of choice for net-zero energy systems of the future.

## **Hydrogen and Greenhouse Gas Emissions.**

Canada currently produces about 8,200 tonnes of hydrogen (H<sub>2</sub>) per day, predominantly by reforming natural gas. This 'gray' H<sub>2</sub> production, which is used as an industrial feedstock to make fertilizer nitrogen and in the petrochemical sector, results in GHG emissions of about 9 kg CO<sub>2</sub>e/kg H<sub>2</sub>.

In moving towards a net-zero energy system, hydrogen would need to be produced with very low or no GHG emissions, and used not only as an industrial feedstock, but as an end use fuel supporting transportation, heat for buildings and industry, and power generation. Low-carbon hydrogen can be produced by the electrolysis of water using low-carbon electricity (from hydro, nuclear or renewables), or from fossil fuels coupled to carbon capture and storage (CCS). Lifecycle emissions from electrolytic 'green' hydrogen range from 0.8 (wind) to 3.4 (solar) kg CO<sub>2</sub>e/kg H<sub>2</sub>, while lifecycle emissions from 'blue' hydrogen made from natural gas with 90+% CCS range from 2 to 3 kg CO<sub>2</sub>e/kg H<sub>2</sub>.

The GHG benefits of blue or green hydrogen use depends, in part, on how the fuel is used. For example, if blue hydrogen is used in a hydrogen fuel cell electric (HFCE) vehicle that displaces a gasoline vehicle, the lifecycle GHG savings are about 89%. In a HFCE vehicle (e.g. truck) that displaces a diesel vehicle, the GHG savings are about 83%, and if hydrogen is used to displace natural gas for heating, the GHG savings are about 67%. Hydrogen can also be used as a dual fuel with diesel (40 H<sub>2</sub> : 60 diesel by energy content), and in this case, the lifecycle GHG savings are about 32% compared to a vehicle using only diesel fuel.



## Executive Summary (Continued)

### **Magnitude of the Opportunity and Challenge.**

Based on a sectoral and regional assessments, we have modeled a near net-zero energy system for Canada in 2050 where the per capita energy demand decreases by one third due to improved energy efficient technologies (e.g. heat pumps and electric motors) and electricity for end-use applications increases from supplying approximately 15% of Canada's primary energy demand in 2017 to approximately 35% in 2050. All new generation (and some existing fossil-carbon generation) would be from very low emitting sources (such as hydropower, nuclear, wind, solar or fossil fuels with CCS). Concurrent with this change, we projected that hydrogen would be the energy carrier for approximately 27% of Canada's primary energy demand in 2050, equivalent to 64 kt H<sub>2</sub>/day.

To meet the additional demand for the direct use of electricity, Canada's new, net-zero energy system requires 700 TWh<sub>e</sub>/yr of new low-carbon electricity in addition to the 400 TWh<sub>e</sub>/yr that currently contributes to the public grid. To supply the hydrogen fuel demands of 64 kt H<sub>2</sub>/day as green hydrogen would require another 1,054 TWh<sub>e</sub>/yr where all that power is dedicated to hydrogen production. This could be met by 66,000 large (4.8MW) wind turbines, or 30 nuclear plants the size of 'Bruce Power' (4,700 MW), or 195 large hydro reservoirs the size of BC's 'Site C' (1,100 MW each).

Alternatively, the 64 kt H<sub>2</sub>/day could be supplied as blue hydrogen using 4,490 PJ of natural gas per year, equivalent to 72% of Canada's current natural gas production. The hydrogen production would be about eight times the current production of hydrogen from natural gas in Canada. The carbon capture and storage requirement for this magnitude of blue hydrogen production would be about 203 Mt CO<sub>2</sub>/yr. Meeting this domestic demand for hydrogen is probably best done through a combination of 'blue' and 'green' hydrogen where the relative importance of each would vary with different regions and sectors across the country.

There are also likely to be significant export markets for blue or green hydrogen in countries like the U.S., Japan, South Korea and Germany. Our analysis suggest that this could easily double the demand for Canada's zero-emission hydrogen production, generating a wholesale market potential for hydrogen of up to \$100B a year, and potentially more.



## Executive Summary (Continued)

### **The Economics and Environmental Footprint of Hydrogen.**

For a net-zero energy system to be credible and compelling, it is ideal if it is priced competitively with the incumbent carbon-based fuel option. To meet this criteria, the retail price target for low or zero-carbon hydrogen should be C\$3.50 to C\$5.00/kg (C\$25-35/GJ<sub>h<sub>h</sub>v</sub>) when used as a transportation fuel. For thermochemical applications, the low cost of incumbent carbon-based fuels makes it more challenging, but retail price target of \$1.00 to \$2.80/kg H<sub>2</sub> (\$7-20/GJ<sub>h<sub>h</sub>v</sub>) should be able to compete if combined with improved energy efficiency and policy measures.

Canada is fortunate to be among the world's lowest cost producers of zero or low-carbon hydrogen. In provinces with ample low-carbon electricity (e.g. from hydropower, nuclear or renewables), electrolysis of water can produce 'green' hydrogen for \$2.50 to \$5.00/kg H<sub>2</sub> (\$18 to \$35/GJ<sub>h<sub>h</sub>v</sub> H<sub>2</sub>). In provinces with low-cost natural gas and the geology suitable for permanently sequestering the byproduct CO<sub>2</sub>, 'blue' hydrogen can be produced at a price of \$1.50 to \$2.0/kg H<sub>2</sub> (\$10 to \$14/GJ<sub>h<sub>h</sub>v</sub> H<sub>2</sub>), not counting the income that can be generated by selling CO<sub>2</sub> for enhanced oil recovery (estimated at \$20/t CO<sub>2</sub>) or from generating [Emission Performance Credits \(EPCs\)](#) under Alberta's [Technology Innovation and Emission Reduction \(TIER\) Program](#) (\$40/t CO<sub>2</sub> in 2021). Such initiatives can reduce the cost of blue hydrogen production by \$0.32/kg H<sub>2</sub> or more, resulting in a wholesale cost of blue hydrogen that is about half the wholesale cost of diesel fuel in Canada, and one third the retail cost.

However, the distribution and retail of a gas like hydrogen is associated with higher costs than for diesel. Requirements under the new federal [clean fuel standard](#) (CFS) could help to level that playing field, by generating credits that are linked to the lifecycle benefits of using blue or green hydrogen to displace GHG emissions from traditional uses for fossil fuels (the British-Columbia version is currently generating credits worth over \$300/t CO<sub>2</sub>e). For example, CFS credits worth \$200/t CO<sub>2</sub>e would mean that displacing natural gas with blue or green hydrogen may reduce retail costs for the fuel by up to \$1/kg H<sub>2</sub>, while using blue hydrogen to displace diesel in a hydrogen-diesel vehicle or in a HFCE vehicle could generate credits of \$1.50+ or \$2.40+/kg H<sub>2</sub>, respectively.

The combination of Canada's abundant resources for blue and green hydrogen production, and a number of existing and emerging policies and standards can make it possible to produce, distribute and retail the hydrogen at a price that is competitive with the fossil fuel alternatives as long as there is sufficient demand for the zero-emission fuel to benefit from the economics of scale.



## Executive Summary (Continued)

### **Realizing the Opportunity.**

A coordinated, system level effort is needed to break the vicious cycle that currently prevents the emergence of the hydrogen economy. In this cycle, the absence of demand for fuel hydrogen is linked to the absence of cost-effective fuel supply. The lack of supply is then linked to the lack of demand and the high cost of the vehicles and other service technologies since their production cannot benefit from the economies of large-scale manufacturing.

This challenge can be addressed by establishing 'hydrogen nodes' in regions across Canada where the following criteria can be met:

- A low-cost, low-carbon source of blue, green or waste hydrogen;
- Substantial nearby markets for the hydrogen as a fuel and/or industrial feedstock;
- Ability to cost-effectively connect supply to demand (pipelines preferred to tube trailers or liquid hydrogen);
- Scale of supply and demand where the economics work without sustained public investment;
- Engaged industry, governments and academics to drive and support the initiative.

The sub-regional scale of this approach (i.e. municipalities, transportation corridors, etc.) and its deployment across Canada can focus public and private investment towards the creation of small, but viable zero-emission energy systems that will grow over time to create the transformative change that is needed for the energy systems of Canada. The deployment and growth of these hydrogen nodes should be coordinated with the opportunity for Canada to provide zero-emission hydrogen to other nations wanting to decarbonize their energy systems. In doing so, Canada can become a global leader in the transition to a net-zero emission energy future.

The Transition  
Accelerator



L'Accélérateur  
de transition

**TOWARDS NET-ZERO ENERGY SYSTEMS IN CANADA:  
*A KEY ROLE FOR HYDROGEN***

1. Introduction



# 1. Introduction

Canada and 72 other nations of the world have committed to [net-zero emissions by 2050](#) to address the challenges of climate change and the desire to [limit global warming to 1.5°C](#). In 2018, Canada's greenhouse gas emissions were 729 Mt CO<sub>2</sub>e/yr ([NIR 2020 report](#)), comprising:

- **Combustion emissions** of 541 Mt CO<sub>2</sub>e/yr, including those associated with electricity and fuel production (192 Mt CO<sub>2</sub>e/yr), and the end use of carbon-based fuels (349 Mt CO<sub>2</sub>e/yr) for transport, buildings or industrial processes
- **Fugitive emissions** from fuel and electricity production (55 Mt CO<sub>2</sub>e/yr)
- **Process emission** from non-energy industries such as cement, etc. (56 Mt CO<sub>2</sub>e/yr)
- **Agricultural emissions**, primarily from nitrous oxide and methane (59 Mt CO<sub>2</sub>e/yr)
- **Waste management** emissions, primarily from methane (18 Mt CO<sub>2</sub>e/yr)

This study focuses on only the emissions from the combustion of fuels (541 Mt CO<sub>2</sub>e/yr or 74% of all emissions), with particular attention to the end-use fuels and energy carriers that are consumed in the tens of millions of individual buildings, engines and industrial processes distributed across Canada. These energy carriers include electricity, gasoline, diesel, kerosene (jet fuel) and natural gas (**Figure 1.1**).

Improvements in energy efficiency and conservation in these end use sectors will be critical but experience to date shows that the strong policies in this area are only able to achieve about a 1% improvement per year, effectively balancing population and economic growth.

Clearly, fundamental changes are needed in the **energy carriers** that are used to move energy resources from where they are produced to where they are used. Moreover, changes in energy carriers can sometimes be linked with improved efficiencies in delivering energy services (e.g. electric heat pumps vs. gas furnaces; electric motors vs. internal combustion engines).

There are three options for decarbonization of energy carriers in Canada, and all three are required in most, if not all credible visions for net-zero emission energy futures ([Davis et al. 2018](#), [Tsiropoulos et al. 2020](#))

- **Electrification** of end use demand, where the electricity is produced with little or no GHG emissions;
- **Biofuels and bioenergy** that can be produced without depleting biosphere carbon stocks;
- **Hydrogen** (or derivatives of hydrogen such as ammonia or synthetic hydrocarbons) where the hydrogen can be produced with little or no GHG emissions.

# 1. Introduction (Continued)

A. Canada's Energy System (2017)

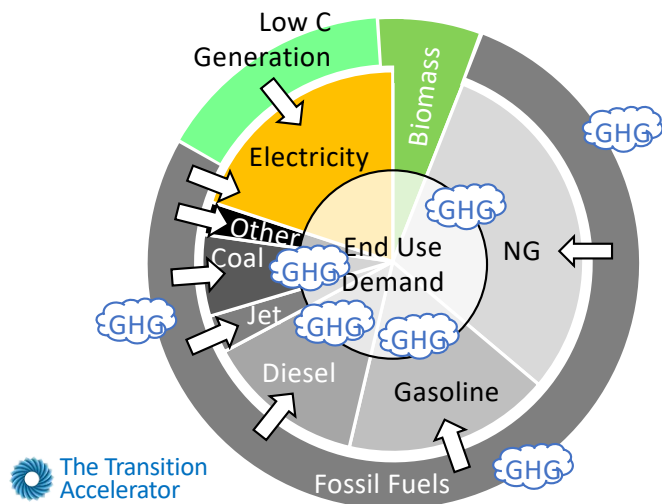

B. Possible Net-Zero Energy System (2050)

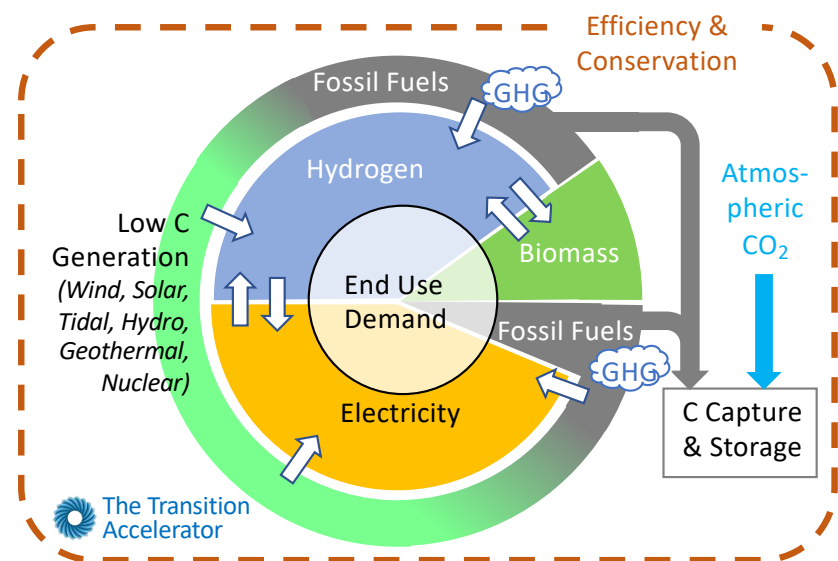

**Figure 1.1.** Comparison of Canada's energy system in 2017 (A), and a possible net-zero emission energy system in the future (B). End use demand for energy is provided by energy carriers that must be zero-emission in the future. The production of these energy carriers must also be greatly reduced or eliminated. GHG, greenhouse gas. Panel A from [NRCan Comprehensive Energy Database](#). There is no consensus on the relative importance of the various energy sources or end use fuels or electricity.

## 1. Introduction (Continued)

Negative emission technologies, such as building forest and agricultural carbon stocks, or air capture of CO<sub>2</sub> coupled to carbon capture and storage, will also play a role in offsetting the GHG emissions that do occur. In the case of efforts to increase biosphere carbon stocks, this role needs to be balanced with the previously mentioned demand for biomass for biofuels and bioenergy.

Changing the energy carriers that are used to fulfill end-use demand will also reduce the market for traditional fuels and the GHG-intense processes currently involved in their production. It is clear that creating demand for credible and compelling zero-emission energy carriers is essential to Canada's transition to net-zero emission energy systems.

In this report, we are focused on the challenges and opportunities associated with the production, distribution and use of low or zero-carbon hydrogen as a fuel in Canada's net-zero emission energy future (See **Box 1.1**). Hydrogen already plays a significant role in the energy systems of Canada, primarily as an industrial feedstock. This includes the production of ammonia fertilizer, the conversion of bitumen into synthetic crude oil, and the production of traditional fuels and other refined petroleum products from oil (**Figure 1.2**).

Across Canada, hydrogen production is estimated to be about 3 million tonnes (Mt) per year or 8,200 t H<sub>2</sub>/day. Most of the hydrogen is made from natural gas through a process called steam-methane reforming (SMR) where the CO<sub>2</sub> byproduct is released into atmosphere with GHG emissions of approximately 27 Mt CO<sub>2</sub>e/yr, equivalent to about 4% of Canada's GHG emissions.

It is worth noting that hydrogen is also produced as a byproduct of some chemical processes (e.g. [chlor-alkali plants](#)), so that gas could provide another potential source of hydrogen for a new energy system (**Figure 1.2**).

### BOX 1.1. About Hydrogen

Hydrogen (H) atoms account for 75% of all the atoms in the universe.

Two atoms connected makes hydrogen gas (H<sub>2</sub>), an energy rich molecule. When reacted with oxygen gas (O<sub>2</sub>, from air) only water (H<sub>2</sub>O) is formed.

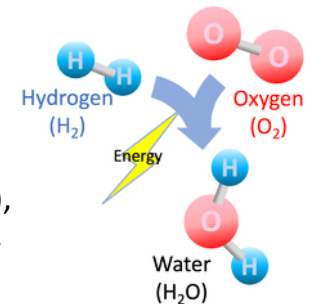

If the two gases come together in combustion, HEAT is formed. However, if they come together in a fuel cell, mostly ELECTRICITY (some HEAT) is created.

Electricity can also be used to create hydrogen through the electrolysis of water.

So hydrogen and electricity can complement each other as energy carriers, ultimately contributing to a more robust energy system (see [Dowling et al. 2020](#)).





# 1. Introduction (Continued)

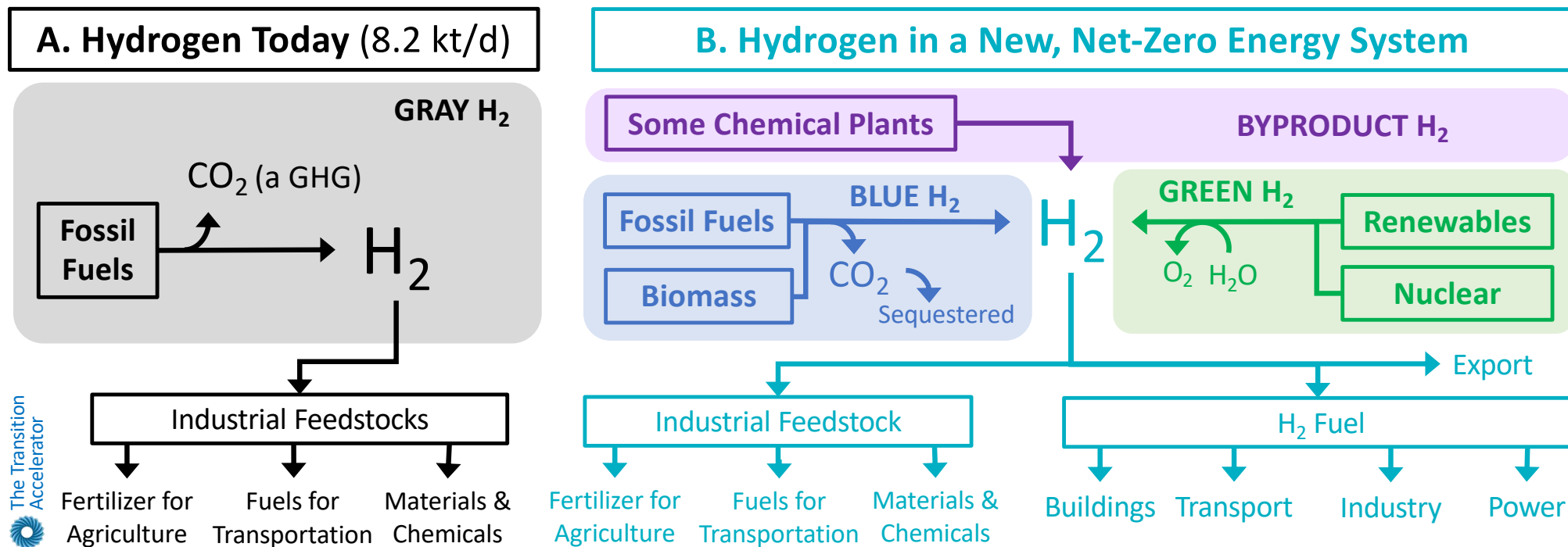

**Figure 1.2.** Comparison of the role hydrogen currently plays in the energy systems of Canada (A), and its possible role in a future net-zero energy system (B) as a fuel.



# 1. Introduction (Continued)

In a new, net-zero energy system, the emissions associated with hydrogen production must be dramatically reduced or eliminated, and hydrogen will need to move beyond its limited role as an industrial feedstock. As shown in **Figure 1.2**, we envisage that the transition to a new net-zero energy systems will involve:

- a) Reducing by 90% or more, the GHG emissions associated with H<sub>2</sub> production from fossil fuels by coupling it with carbon capture and storage (CCS). Hydrogen could also be made from biomass and if coupled to CCS, it could have negative GHG emissions. H<sub>2</sub> produced in this way is referred to as 'blue' H<sub>2</sub>.
- b) Producing 'green' H<sub>2</sub> from water electrolysis with low or zero-emission power (e.g. hydro, nuclear, wind, solar).
- c) Diverting byproduct H<sub>2</sub> from certain chemical plants (e.g. chlor-alkaloi plants) to new fuel markets for the fuel ([Ref](#)).
- d) Expanding the use of hydrogen as an industrial feedstock, including into other sectors (e.g. steel making, glass production, etc.)
- e) Creating large new markets for H<sub>2</sub> as a fuel for sectors such as space heating, transport, heavy industry, and power generation. [Recent work](#) has highlighted the potential role for H<sub>2</sub> in providing seasonal storage of renewable power in regions where there are large annual variations in energy supply and demand.

In recent years, countries around the world have been developing strategies and roadmaps for the deployment of a hydrogen economy, some of which can be seen in **Box 1.2**. While these strategies respond to concerns about global climate change and the international commitment to limit global climate change to 1.5°C, they also align with concerns about air pollution, especially from the combustion of diesel fuel for freight movement, and with a desire to build future economic growth around infrastructure and technologies that are not at risk of being stranded by transformative energy system change. Canada's hydrogen strategy is currently in preparation for a fall 2020 release.

This report begins by exploring the cost of green and blue hydrogen production in Canada (**Section 2**), and then provides a techno-economic and lifecycle environmental assessment of possible future energy systems in which hydrogen displaces traditional fossil fuels for transportation or space heating (**Section 3**). **Section 4** explores the domestic and export market potential for hydrogen before the results are discussed and a conclusion is provided (**Section 5**).

## BOX 1.2 A Selection of Regional and National Hydrogen Strategies and Roadmaps

Australia  
Germany  
United Kingdom  
Japan  
United States  
Norway  
South Korea  
New Zealand  
Denmark  
EU Hydrogen  
Council  
Portugal  
International  
Energy Agency  
China  
North Africa  
Canada



The Transition  
Accelerator



L'Accélérateur  
de transition

**TOWARDS NET-ZERO ENERGY SYSTEMS IN CANADA:  
*A KEY ROLE FOR HYDROGEN***

2. The Cost of Hydrogen Production  
in Canada



## 2.1. Setting the Bar

To accelerate the transition to net-zero emission energy systems, it would be ideal if the cost for the alternative, zero-emission energy carriers were the same or less than the cost of the GHG-emitting energy carriers that are used today. Environmental regulations (e.g. carbon pricing) and fuel standards can help to level (or tilt) the playing field, but such policy measures can be polarizing from a political perspective and slow progress. While cost-equivalence for alternative, zero-emission fuels is a ‘high bar’ to set and may not be achievable in all cases, the closer one gets to meeting that metric, the more compelling the alternative, and the faster the transition.

**Table 2.1** provides details on the current range of wholesale and retail prices associated with the three energy systems that currently provide Canada’s societal needs, including transportation fuels, thermo-chemical fuels and electricity. To allow comparisons, all energy units have been converted to 2018 Canadian dollars per gigajoule of higher heat value energy (C\$/GJ<sub>h<sub>h</sub>v</sub>).

In the case of transportation fuels like gasoline and diesel, the current wholesale price is C\$14-24/GJ<sub>h<sub>h</sub>v</sub>, and the retail price (including transportation costs and taxes) is C\$24-41/GJ<sub>h<sub>h</sub>v</sub>. We have set a target retail price for blue H<sub>2</sub> at C\$25-35/GJ<sub>h<sub>h</sub>v</sub> (C\$3.50-5.00/kg H<sub>2</sub>) for fuel cell grade, compressed gas (**Table 2.1**).

Thermo-chemical fuels, such as those used for space, water and industrial heating currently sell for significantly less than transportation fuels, ranging from C\$1-10/GJ wholesale and C\$5-20/GJ retail (**Table 2.1**).

**Table 2.1.** Comparison of the existing wholesale and retail price ranges for fuels and electricity with targeted retail prices for hydrogen to be competitive in the marketplace. All values are in Canadian dollars (current) and existing fuel and electricity prices are for the 2010-2020 period. Retail prices include distribution costs and taxes.

Fuel or Electricity Market		Wholesale Price			Retail Prices			Target H <sub>2</sub> Retail Price	
		Value	Units	\$/GJ <sub>h<sub>h</sub>v</sub>	Value	Units	\$/GJ <sub>h<sub>h</sub>v</sub>	\$/GJ <sub>h<sub>h</sub>v</sub>	\$/kg H <sub>2</sub>
Transportation Fuels (Gasoline, diesel, kerosene)	Low	\$0.50	\$/L	<b>\$14</b>	\$0.90	\$/L	<b>\$24</b>	<b>\$25</b>	<b>\$3.50</b>
	High	\$0.90	\$/L	<b>\$24</b>	\$1.50	\$/L	<b>\$41</b>	<b>\$35</b>	<b>\$5.00</b>
Thermo-chemical Fuels (Natural gas, coal, biomass)	Low	\$1.00	\$/GJ	<b>\$1</b>	\$5.00	\$/GJ	<b>\$5</b>	<b>\$7</b>	<b>\$1.00</b>
	High	\$10.00	\$/GJ	<b>\$10</b>	\$20.00	\$/GJ	<b>\$20</b>	<b>\$20</b>	<b>\$2.80</b>
Electricity (all sources)	Low	\$20.00	\$/MWh	<b>\$6</b>	\$80.00	\$/MWh	<b>\$22</b>	-	-
	High	\$150.00	\$/MWh	<b>\$42</b>	\$300.00	\$/MWh	<b>\$83</b>	-	-



## 2.1. Setting the Bar (Continued)

Since hydrogen being used as a thermochemical fuel is combusted, it does not need to be fuel cell grade nor at the pressures needed by transportation fuels. Therefore, we have set a target retail price for zero-emission H<sub>2</sub> in this sector at C\$7-20/GJ<sub>h<sub>h</sub>v</sub> (C\$1.00-2.80/kg H<sub>2</sub>) for pipeline-delivered gas.

The retail price for electricity tends to be highly variable in space and time compared to other energy carriers, largely dependent on the balance between supply and demand. However, hydrogen can both be made from electricity (via electrolysis) and be converted into electricity (via fuel cells or gas turbines, etc) so they have the potential to complement each other in net-zero energy systems of the future.

For some end use sectors or regions either hydrogen or electricity will be more convenient, cost-competitive or environmentally sustainable than the other and will prevail. For example, personally-owned light duty vehicles seem to be migrating to plug-in electric and electrically powered heat pumps hold great promise for heating and cooling in the more moderate regions of Canada. However, hydrogen is emerging as the fuel of choice for heavy-duty transport since plug-in battery electric heavy-duty vehicles are challenged by energy storage capacity, vehicle weights, recharge times and infrastructure requirements. Also, in regions where there are large annual variations in energy demand (e.g. space heating in colder parts of Canada), the ability to cost effectively store energy as hydrogen in salt caverns and deliver it through new or retrofitted natural gas pipelines, could make hydrogen more viable than electrification alternatives.

In this section, we carry out a high-level assessment of the ability of Canada to produce and retail hydrogen at the price targets identified in **Table 2.1**.

## 2.2. An International Perspective

Canada is internationally recognized as among the world's lowest cost sources of 'blue' and 'green' hydrogen. Of all pacific rim countries, Canada has been identified as the lowest cost producer of green hydrogen (Figure 2.1), capable of making hydrogen at an energy price equivalent to the wholesale cost of diesel.

Provinces like Quebec and Manitoba, with low-carbon, hydro-power grids that produce surplus electricity should be able achieve this price.

For the production of Blue H<sub>2</sub> from natural gas, the Western Canadian Sedimentary Basin (WCSB, includes Northern BC, Alberta and S Saskatchewan) is the ideal location due to the supply of low-cost natural gas, and a geology that can safely store the CO<sub>2</sub> byproduct safely

In this region, it should be possible to produce blue H<sub>2</sub> (90% capture) at a wholesale cost of C\$10/GJ<sub>h<sub>h<sub>v</sub></sub></sub>, one half the wholesale, and one third the retail cost of diesel (Figure 2.1).

**Figure 2.1.** A comparison of the cost of blue or green hydrogen production from countries in the Asia-Pacific region. Adapted from [Asia Pacific Energy Research Centre. 2018. Perspectives on H<sub>2</sub> in the APEC Region. \(Figure 3.\)](#). The vertical shaded regions depict ranges for recent wholesale and retail costs of diesel use in Canada.

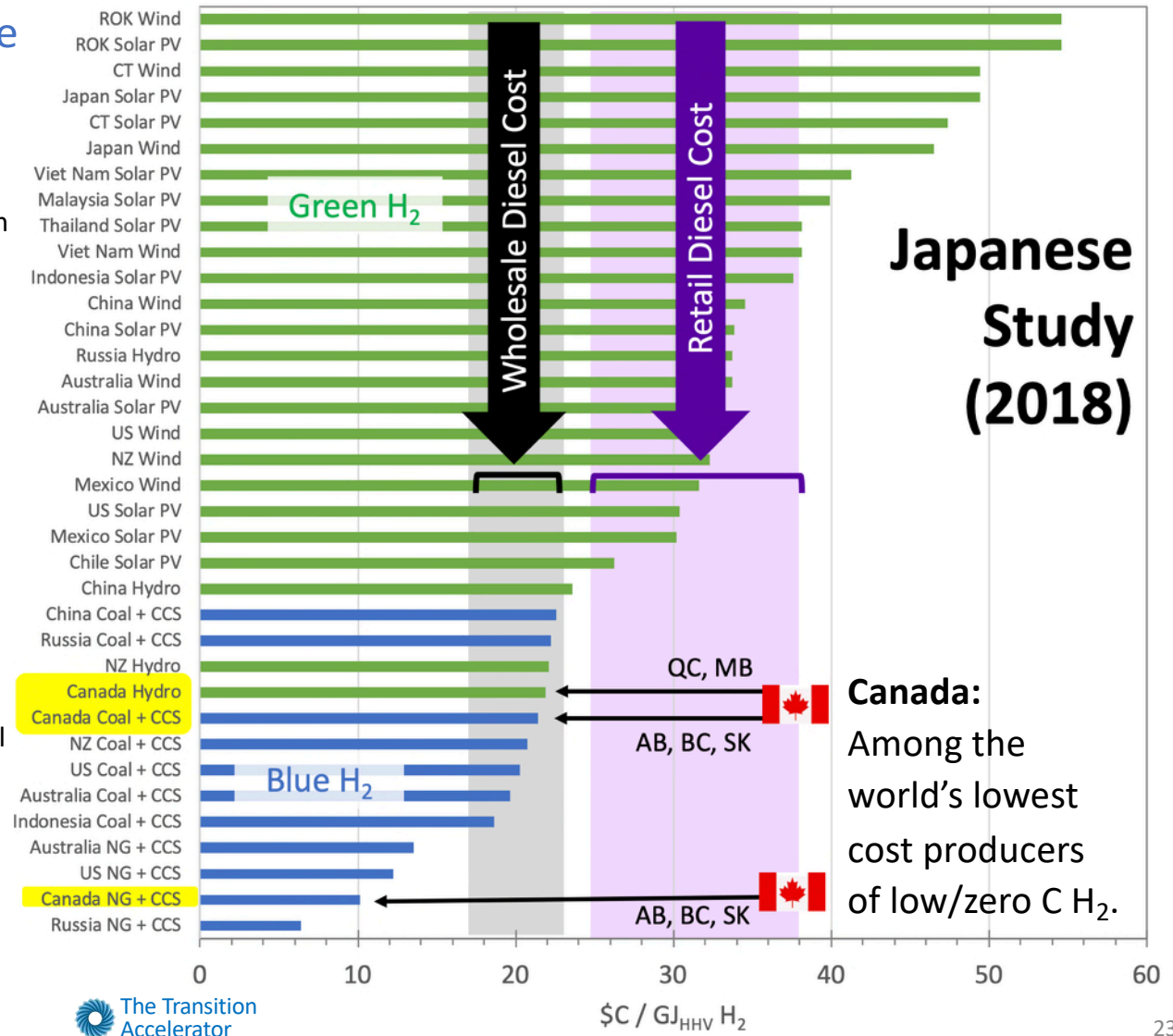

## 2.3. Electrolytic Hydrogen Production

Electrolysis creates hydrogen ( $H_2$ ) and oxygen ( $O_2$ ) from water using electricity. In our analysis we focused on the costs for a Polymer Electrolyte Membrane / Proton Exchange Membrane (PEM) electrolyzer because a number of studies ([Benziger et al. 2006](#), [Ramsden et al. 2013](#)) consider them better suited for use with intermittent power sources. Model parameters from the [International Energy Agency's Future of Hydrogen \(2017\)](#) report were adapted for Canadian currency to illustrate the effect of electricity price and use factors (number of hours per year) on the cost of hydrogen production today, by 2030 and in the future when technology deployment is mature (**Figure 2.2A to C**).

Using the IEA model, three case studies were explored, and the results shown on the surface plot and bar charts in **Figure 2.2**:

- ❑ **Dedicated intermittent renewable** (e.g. wind) with a capacity factor of 34% (3,000 hr/year) where the levelized cost of electricity (LCOE) is \$40/MWh now, but declines to \$30/MWh by 2030;
- ❑ **Low carbon grid power** accessed for 6,000 hr/year (68% capacity factor for electrolyzer) at a delivered electricity price of \$80/MWh;
- ❑ **Low carbon grid power** accessed for 6,000 hr/year (68% capacity factor for electrolyzer) at a delivered electricity price of \$20/MWh. This is the least likely of the three alternatives, only being possible in jurisdictions that often have excess large hydro or nuclear power.

For electrolytic hydrogen production over the next 10 years, the wholesale cost for green hydrogen may decline to as little as C\$3/kg (C\$21+/GJ<sub>h<sub>h<sub>v</sub></sub></sub>). Given that there are substantial costs associated with transporting, compressing and delivering the hydrogen to customers, achieving the \$3.50/kg  $H_2$  target price for a retail transportation will be a challenge. However, with sufficient scale and in the right location and policies, it may be possible to meet the C\$5/kg  $H_2$  retail price target for transportation fuels.

However, with technology and manufacturing improvements that come from large scale deployment of renewable electricity generation, and electrolysis technologies, the viability of green  $H_2$  production [should dramatically improve](#) (**Figure 2.2C**).





## 2.3. Electrolytic Hydrogen Production (Continued)

### A. Today

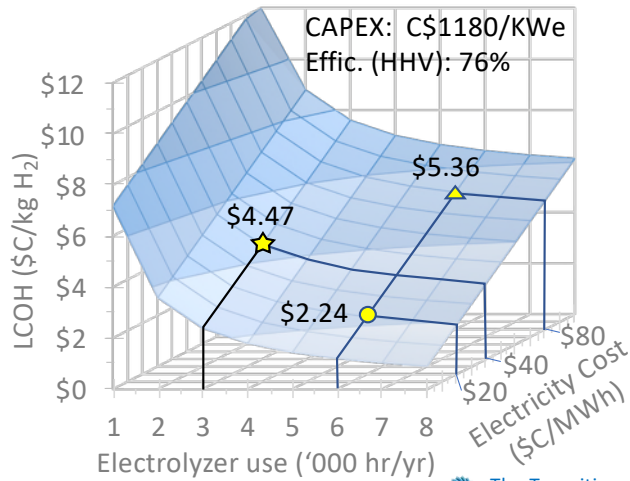

The Transition Accelerator

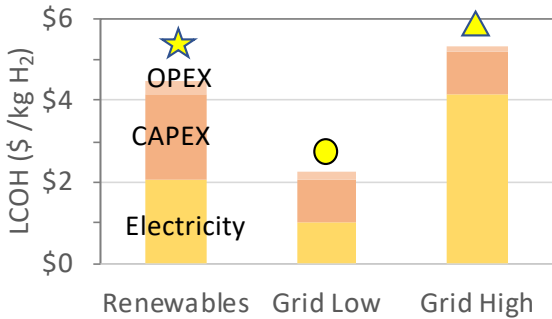

### B. 2030

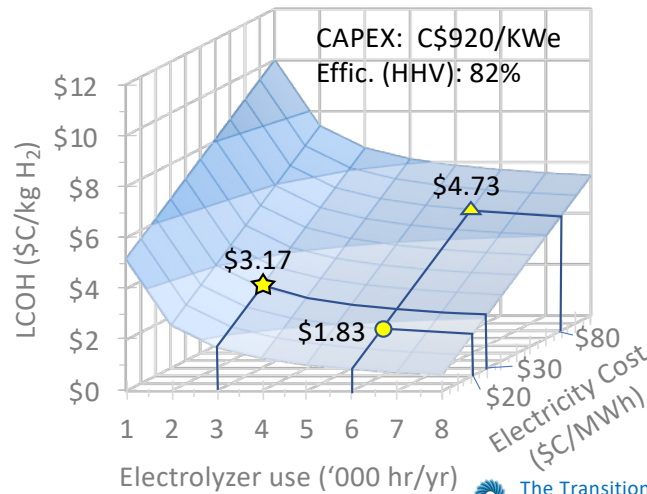

The Transition Accelerator

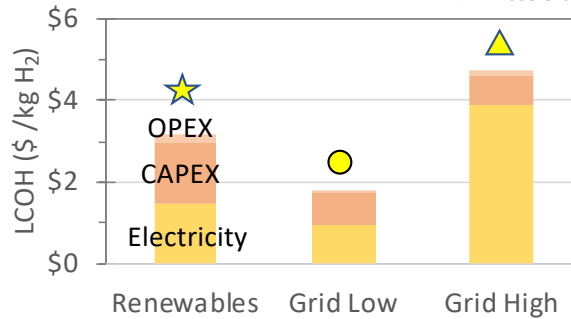

### C. Future

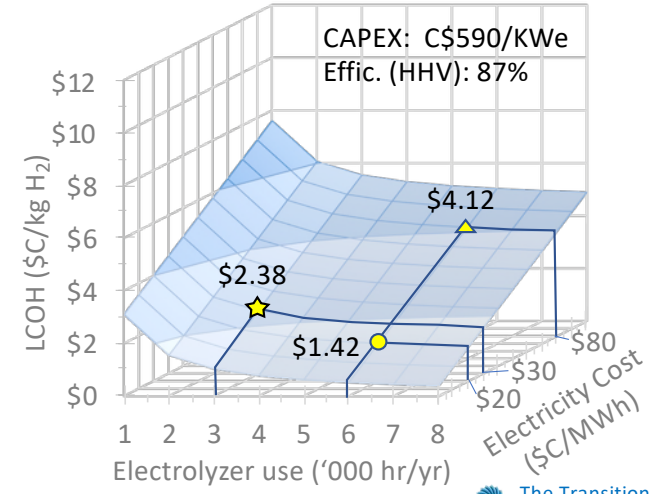

The Transition Accelerator

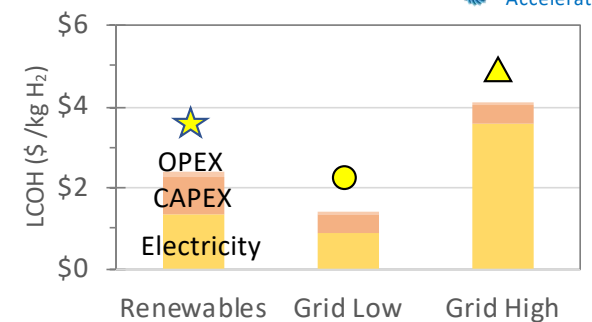

**Figure 2.2.** The effect of electricity cost and capacity factor on the levelized cost of hydrogen (LCOH) production for a 4.2 MW PEM Electrolyzer today (A), in 2030 (B) and in the future (C) when the market is mature. Symbols refer to the three cases described in text. Model adapted from the [IEA Future of Hydrogen \(2017\) report](#). 25



## 2.4. Hydrogen Production from Methane Reforming with CCS

Reforming of natural gas (predominantly methane) dominates hydrogen production in Canada, and the process can be modified to prevent the atmospheric release of 90% or more of the byproduct CO<sub>2</sub>. When methane reforming is coupled to carbon capture and utilization/storage (CCUS) the product is called ‘blue’ hydrogen.

As summarized in **Box 2.1**, there are two major technologies for blue hydrogen production: steam methane reforming (SMR) with CCS and auto-thermal reforming (ATR) with CCS.

Other technologies for production of blue hydrogen include biomass or coal gasification coupled to CCS, or methane pyrolysis to hydrogen and carbon black. While coal gasification is a mature technology, the others are not yet as mature or economically viable as SMR-CCS and ATR-CCS.

Canada is currently one of the lowest cost places to produce hydrogen with minimal greenhouse gas emissions (**Figure 2.1**). Reasons include (a) inexpensive natural gas in Western Canada (**Figure 2.3**), (b) Alberta-owned pore space for permanent CO<sub>2</sub> storage, (c) technical and industry expertise, and (d) carbon pricing regimes.

**Figure 2.4** provides a breakdown of the estimated costs for blue hydrogen production (including CCS) from natural gas today (**Figure 2.4A**), by 2030 (**Figure 2.4B**), and in a future, mature hydrogen economy (**Figure 2.4C**).

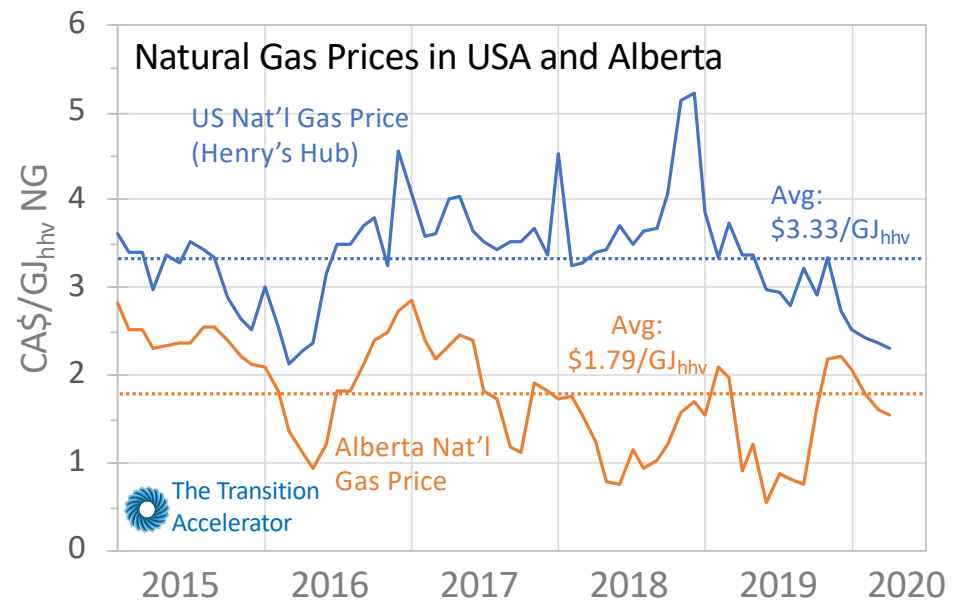

**Figure 2.3.** Comparative prices for natural gas (in \$CA/GJ NG) in the U.S. ([Henry's Hub](#)) and [Alberta](#) over the period of January 2015 to April 2020.



## 2.4. Hydrogen Production from Methane Reforming with CCS (Continued)

### Box 2.1. Natural Gas Reforming with Carbon Capture and Storage (CCS)

#### A. Steam Methane Reforming with CCS

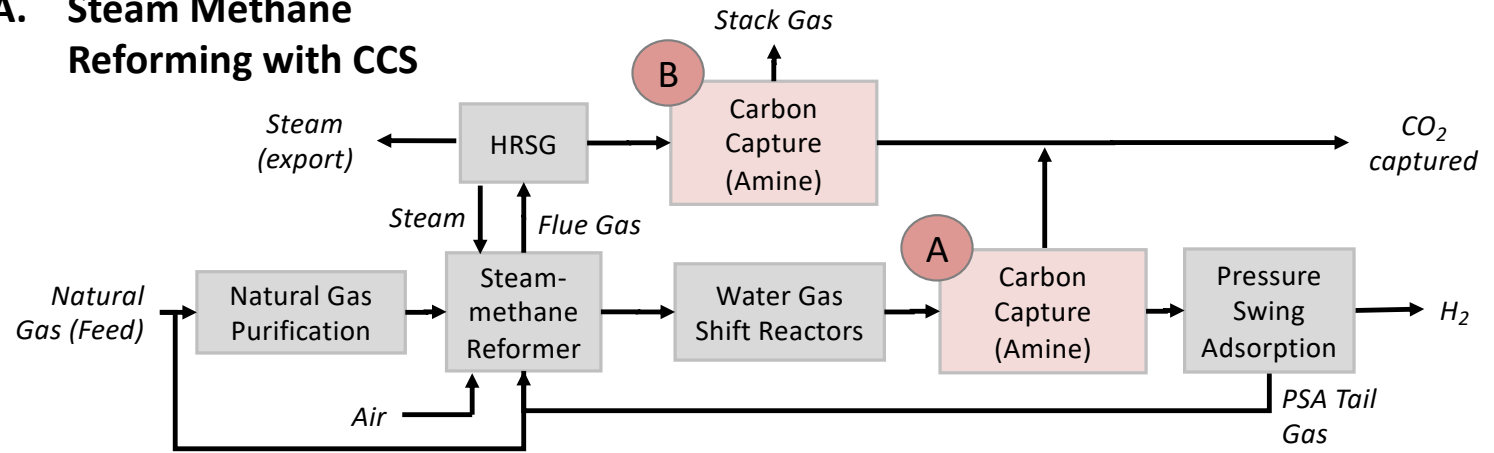

#### B. Auto-thermal reforming with CCS

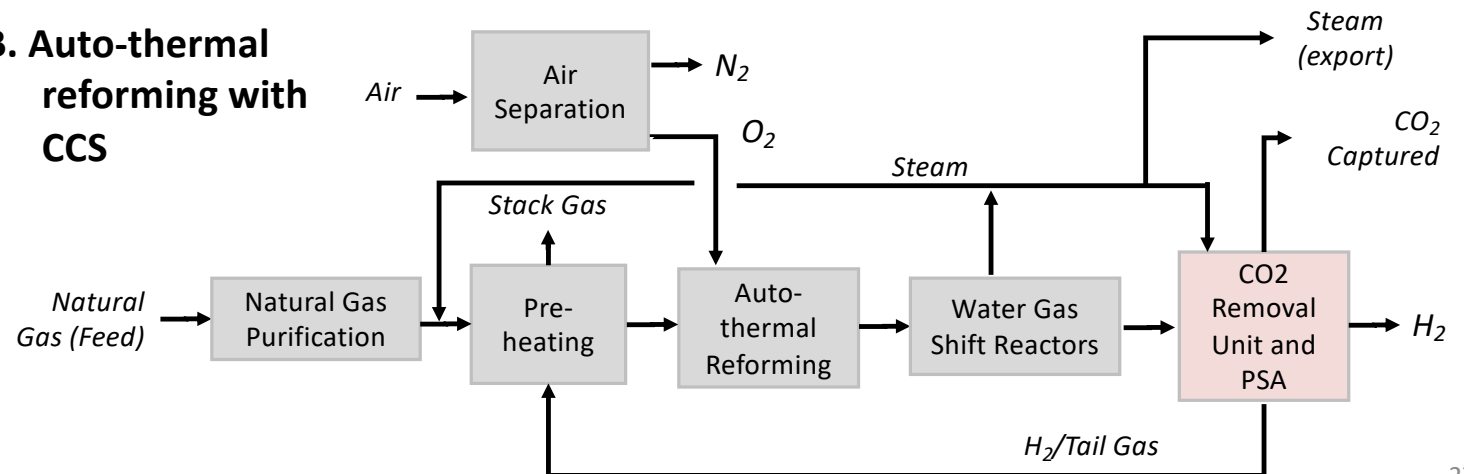



## 2.4. Hydrogen Production from Methane Reforming with CCS (Continued)

### A. Today

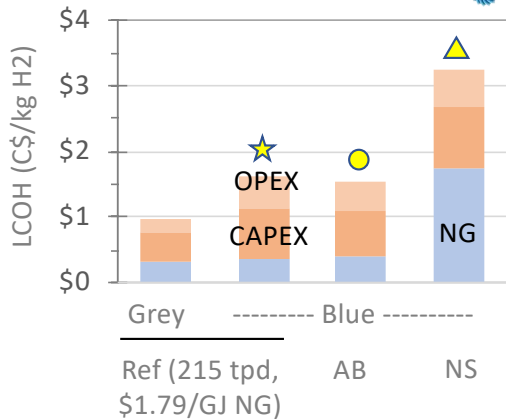
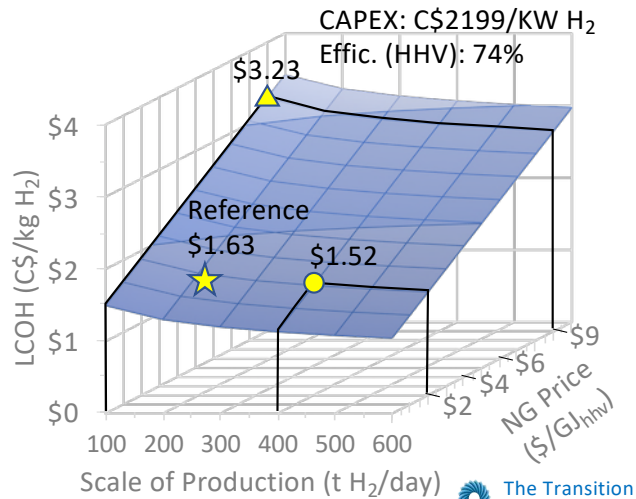

### B. 2030

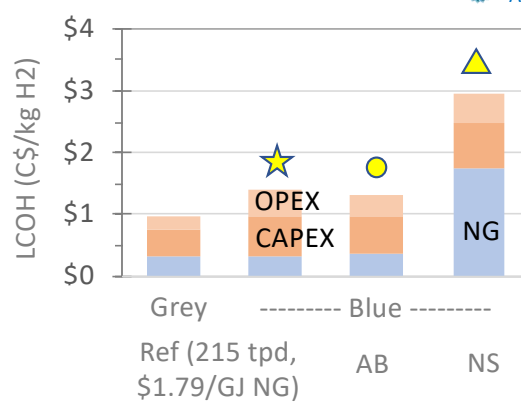
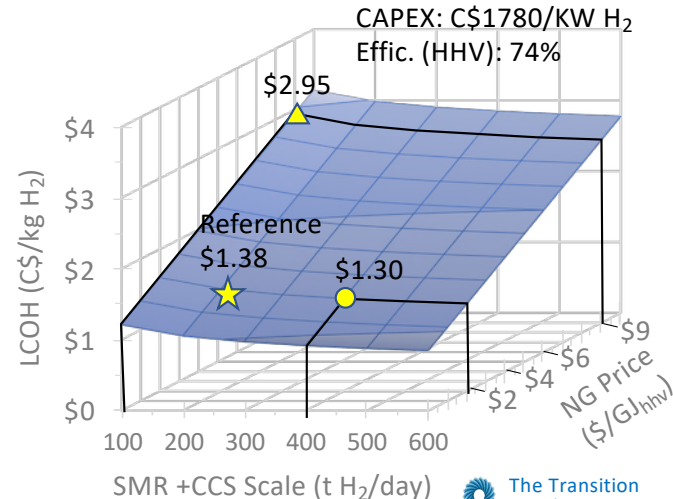

### C. Future

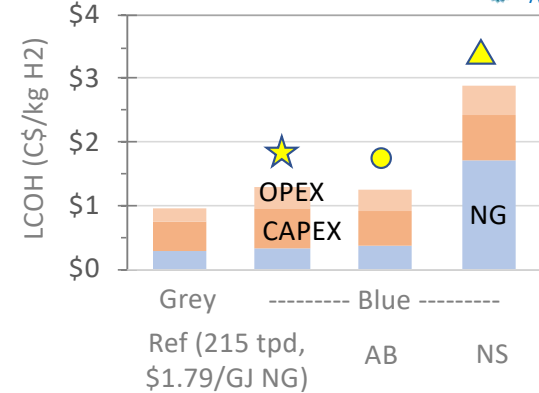
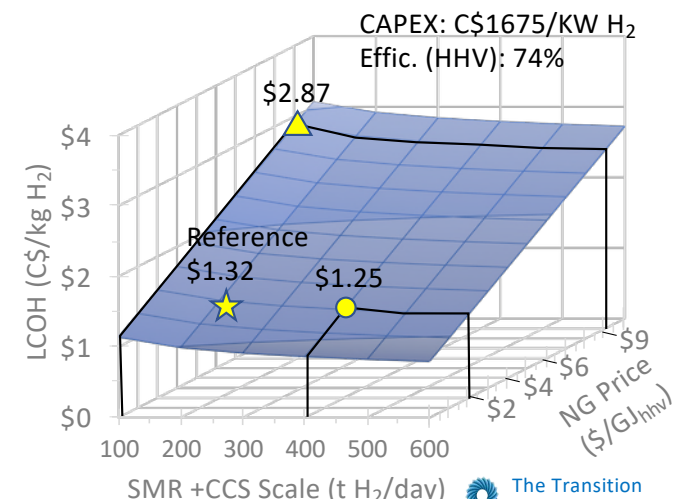

**Figure 2.4.** The effect of natural gas cost and scale of production (tH<sub>2,4</sub>/d) on the levelized cost of hydrogen (LCOH) from a steam methane reformer coupled to carbon capture and storage today (A), in 2030 (B) and in the future (C) when the market is mature. Model adapted from the [IEA Future of Hydrogen \(2017\) report](#).



## 2.4. Hydrogen Production from Methane Reforming with CCS (Continued)

The calculations were based on the [International Energy Agency's 'Future of Hydrogen'](#) model assuming a Canada-US dollar exchange rate of \$C0.76 per \$US1 (average of the last 5 years) and an 8% return on capital cost investment. The upper plots in **Figure 2.4** show the effect of natural gas price (\$0 to \$10/GJ<sub>h<sub>h</sub>v</sub>) and the scale of hydrogen production (100 to 600 t H<sub>2</sub>/d) on the levelized cost of H<sub>2</sub> production. On each surface plot, three case studies are highlighted:

- A reference case based on a 215 t H<sub>2</sub>/day reformer (based on IEA model) and a NG feedstock price of \$1.79/GJ<sub>h<sub>h</sub>v</sub> NG (average of Alberta prices over the last 5 years, **Figure 2.3**);
- An Alberta (AB) scenario assuming a 400 t H<sub>2</sub>/day reformer and a NG feedstock price of C\$2/GJ<sub>h<sub>h</sub>v</sub> ;
- A Nova Scotia (NS) scenario which takes into account a C\$9/GJ<sub>h<sub>h</sub>v</sub> price for natural gas and a smaller (100 t H<sub>2</sub>/day) reformer.

With proven technologies today, the levelized cost of hydrogen (LCOH) for the reference scenario is C\$1.63/kg H<sub>2</sub> (**Figure 2.4A**). With improvements in larger scale deployment of technologies linking H<sub>2</sub> production to carbon capture and storage, the LCOH is projected to decrease to C\$1.38/kg H<sub>2</sub> by 2030 (**Figure 2.4B**) and eventually to C\$1.32/kg H<sub>2</sub> (**Figure 2.4C**).

Note that even in markets like Nova Scotia with high prices for natural gas, the LCOH for blue hydrogen is similar to, or lower than, the cost of green hydrogen (**Figure 2.2**). However, the cost reductions for green hydrogen production over the next 10-20 years are [projected to be steeper than that for blue hydrogen](#), so green hydrogen could easily out-compete blue hydrogen production costs in such markets by 2030 and beyond.

The bar charts in **Figure 2.4A** compare today's LCOH for gray and blue hydrogen production, showing a differential cost of C\$0.65/kg. This translates to a CCS cost of C\$74.37/t CO<sub>2</sub>. While this CCS cost is low compared to many estimates for post combustion CCS costs from coal etc., it does not take into consideration the other income that could be generated from selling the CO<sub>2</sub> into markets that could use it, or in generating CO<sub>2</sub> credits from government programs. These will be considered later in this report, following an assessment of the life cycle footprint associated with hydrogen production.

The Transition  
Accelerator



L'Accélérateur  
de transition

**TOWARDS NET-ZERO ENERGY SYSTEMS IN CANADA:  
*A KEY ROLE FOR HYDROGEN***

3. Emissions Intensity and Life Cycle  
Implications for Hydrogen



## 3.1. Emissions Intensity

Like electricity, hydrogen is an energy carrier that produces no greenhouse gas (GHG) emissions when consumed to provide energy services. However, there can be substantive GHG emissions associated with the production of these energy carriers, as shown in **Figure 3.1**.

If 'gray' hydrogen is produced by steam methane reforming of natural gas, for every kg of H<sub>2</sub> produced, 9 kg CO<sub>2</sub> are associated with the H<sub>2</sub> production and another 1.72 kg CO<sub>2</sub>e/kg H<sub>2</sub> is associated with the upstream (NG recovery) and infrastructure emissions (**Figure 3.1**). While there are various ways to capture and store the byproduct CO<sub>2</sub> to make blue hydrogen from natural gas, in this study we define blue H<sub>2</sub> as 90% CCS from steam methane reforming resulting in net production emissions of 0.97 kg CO<sub>2</sub>/kg H<sub>2</sub>. When combined with upstream and infrastructure emissions of 1.84 kg CO<sub>2</sub>e/kg H<sub>2</sub>, the total emissions are 2.8 kg CO<sub>2</sub>/kg H<sub>2</sub> (**Figure 3.1A**).

This is a similar GHG emission intensity to hydrogen production from biomass (2.7 kg CO<sub>2</sub>/kg H<sub>2</sub>; [Mehmeti et al 2018](#))(**Figure 3.1A**), and less than green hydrogen produced from solar PV if the lifecycle emissions include those associated with making the solar panels (3.4 kg CO<sub>2</sub>/kg H<sub>2</sub>; [IPCC SR15](#))(**Figure 3.1B**). In comparison, life cycle emissions associated with green hydrogen from wind, large hydro and nuclear are about 1 kg CO<sub>2</sub>/kg H<sub>2</sub> and the carbon footprint of hydrogen made from electricity produced by fossil fuels ranges from 23 to 53 kg CO<sub>2</sub>e/kg H<sub>2</sub>.

If the goal is to encourage the production and use of energy carriers that have very low or zero GHG emissions, classifying the 'colours' of hydrogen should be replaced by a classification system that is based on the life cycle carbon intensity. However, since there is no consensus to date on the how to measure and rank the GHG intensity of hydrogen, we will continue to use the 'blue' and 'green' hydrogen designations in this report.



### 3.1. Emissions Intensity (Continued)

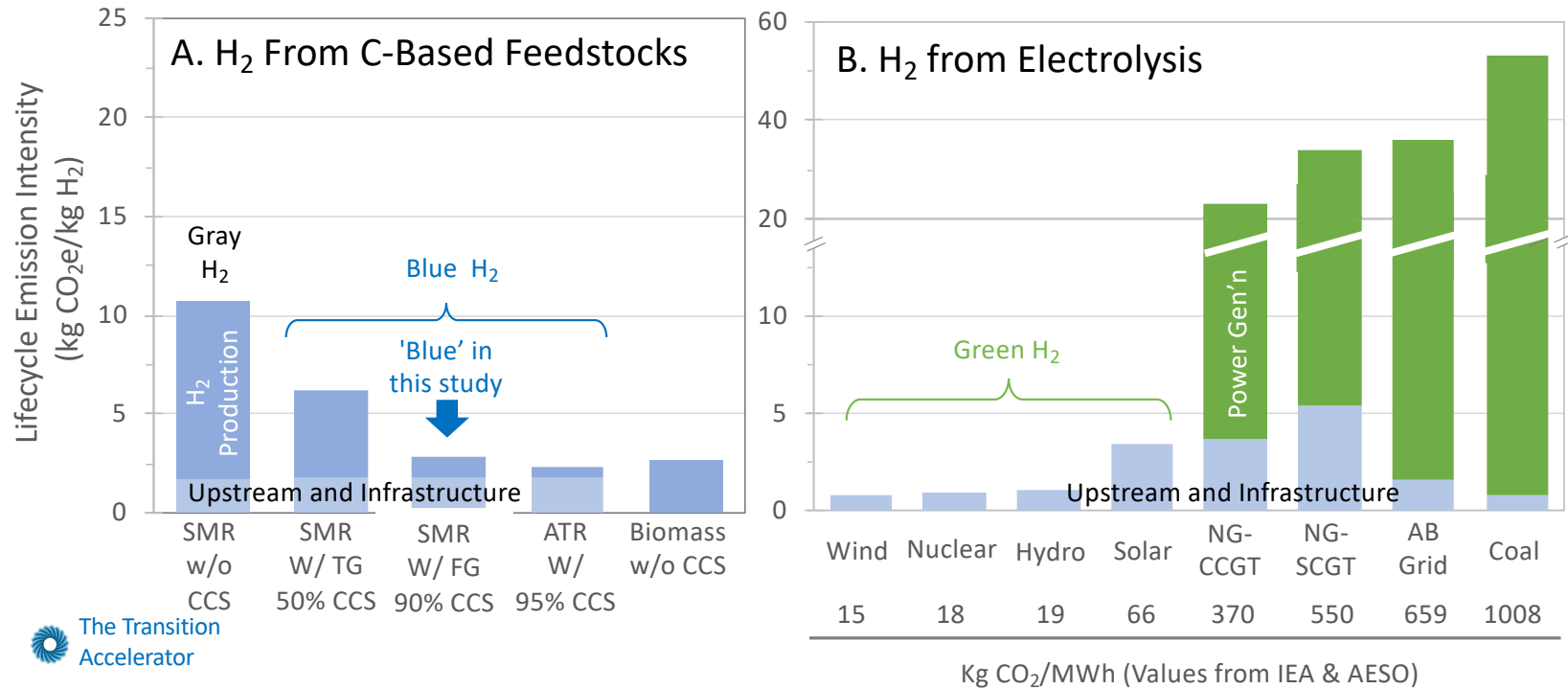

**Figure 3.1.** The greenhouse gas (GHG) emissions intensity for Hydrogen (H<sub>2</sub>) production from C-based feedstocks (A) and water electrolysis (B). Values calculated from data extracted from from [IEA Future of Hydrogen](#), [IPCC SR15](#) and [AESO](#). Biomass life cycle assessment from [Mehmeti et al 2018](#).





## 3.2. Drivetrain Efficiency Comparison

When H<sub>2</sub> is used as a transportation fuel to replace diesel or gasoline, the drivetrain may also change from an internal combustion engine (ICE) to a hydrogen fuel cell electric (HFCE) hybrid drivetrain.

As shown in **Figure 3.2 A**, the HFCE drivetrain tends to be more efficient than an ICE in converting a gigajoule of fuel energy into a gigajoule of kinetic energy. This is especially true for gasoline ICEs which are typically not as efficient as diesel engines.

The drive cycle of the vehicles is also important since stop and go traffic gives the HFCE vehicles an energy advantage through regenerative breaking.

In this study, we used the average of the possible range of drive train efficiency ratios (i.e. ICE:HFCE) to assign a value of 0.86 GJ H<sub>2</sub>/GJ diesel for diesel vehicles and a value of 0.56 GJ H<sub>2</sub>/ GJ gasoline for gasoline vehicles (**Figure 3.2B**).

These numbers were combined with the carbon intensity data in **Figure 3.1** to calculate the lifecycle GHG emissions reductions associated with blue hydrogen (90% CCS) displacing diesel fuel in either a H<sub>2</sub>-diesel ICE dual-fuel vehicle or a HFCE vehicle (**Figure 3.3**).

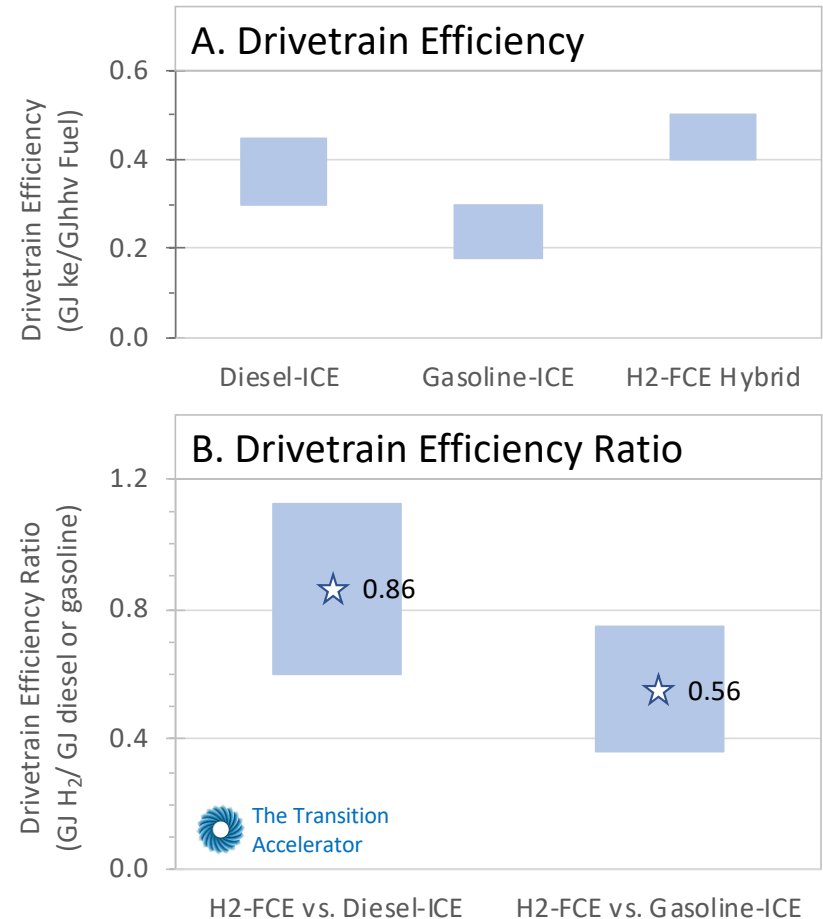
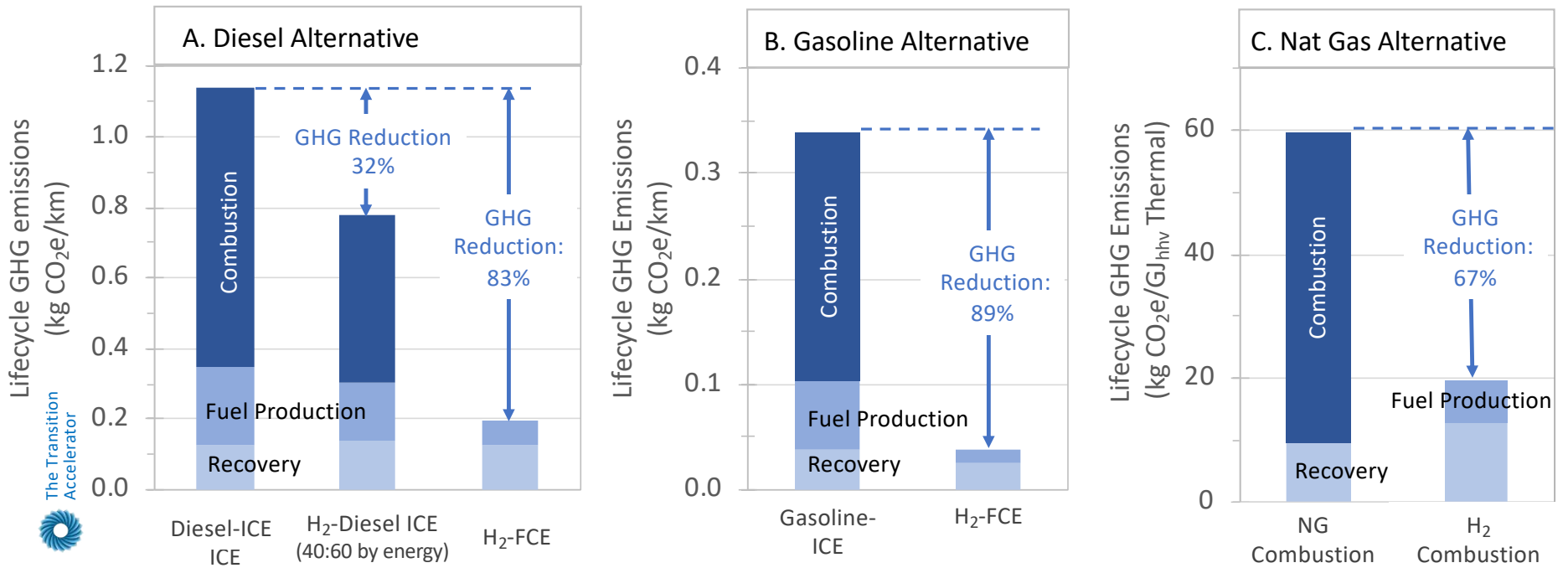

**Figure 3.2.** Range of drive train efficiencies (GJ of kinetic energy to wheels per GJ of fuel) (A) and the ratio of ICE to HFCE vehicles was used to calculate the drivetrain efficiency ratio (B).



### 3.3. Lifecycle Emission Reductions with Blue Hydrogen

If blue H<sub>2</sub> is used with a HFCE vehicle to replace a gasoline internal combustion engine (ICE) vehicle, the low drivetrain efficiency ratio (**Figure 3.3B**) and the low life cycle emission intensity (**Figure 3.1A**) result in an estimated 89% reduction in per km emissions. The higher drivetrain efficiency of diesel means that proportional GHG benefits of HFCE in diesel vehicles amount to an 83% reduction in per km emissions compared to a diesel vehicle (**Figure 3.3A**). Alternatively, retrofitting a diesel engine to accept 40% of the fuel energy as blue H<sub>2</sub> (balance of fuel is diesel) there is an overall 32% reduction in per kilometre emissions compared to a 100% diesel vehicle (**Figure 3.3A**). Replacing natural gas with blue H<sub>2</sub> for space and water heating reduces lifecycle GHG emissions by 67% compared to natural gas (**Figure 3.3C**).



**Figure 3.3.** Emission reduction potential associated with using 'blue' hydrogen (90% CCS) as an alternative fuel for diesel in a heavy-duty vehicle (A), gasoline in a light duty vehicle (B) or natural gas for thermo-chemical energy demands (C). Details of calculations are provided in **Appendix A1**.



## 3.2. Lifecycle Emission Reductions with Blue Hydrogen (Continued)

With blue hydrogen, the significant proportion of the lifecycle emissions are associated with methane losses to the atmosphere in the natural gas recovery processes. Reducing these emissions would play a major role in reducing the lifecycle emissions associated with blue hydrogen production.

Drawing on the results of **Figure 3.1 A** and **Figure 3.3**, it is possible to compare the magnitude of carbon captured and utilized/stored (CCUS, 9 kg CO<sub>2</sub>/kg H<sub>2</sub>) with the net lifecycle GHG benefits gained by using that carbon to displace fossil fuel energy carriers in various markets. For example, using blue hydrogen to replace natural gas in building space and water heating returns a lifecycle GHG reduction benefit of 5.7 kg CO<sub>2</sub>/ kg H<sub>2</sub>. However, with the elimination of tailpipe emissions, using the hydrogen to displace diesel in a H<sub>2</sub> diesel dual-fuel vehicle, or in a HFCE vehicle would return a GHG benefit of 11.1 or 13.4 kg CO<sub>2</sub>e/kg H<sub>2</sub>, respectively (**Figure 3.4**). Replacing a gasoline-ICE vehicle with a HFCE vehicle could result in a 22.3 kg CO<sub>2</sub> benefit per kg H<sub>2</sub> (**Figure 3.4**).

Therefore, it is possible to use CCUS to achieve 1.2 to 2.5 times more than the magnitude of the carbon sequestered. This is because hydrogen made from natural gas is displacing a more carbon intense fuel and potentially achieving greater drivetrain efficiency.

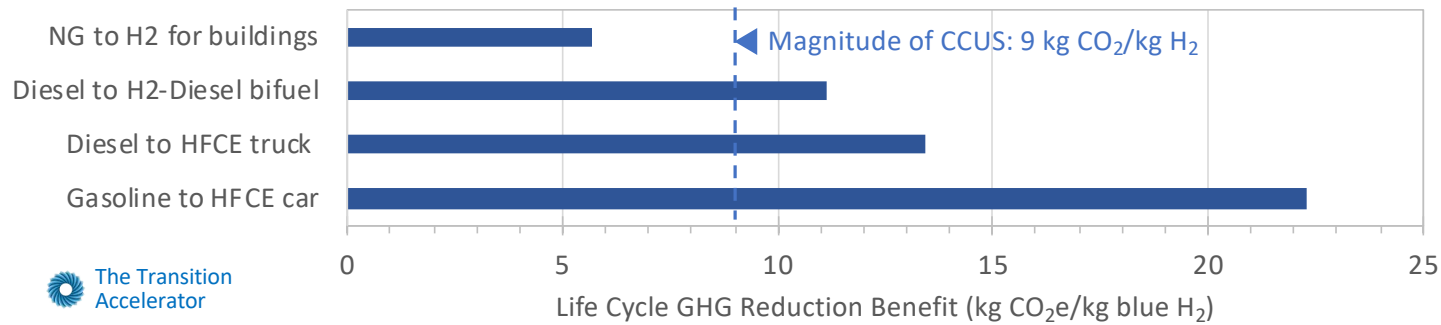

**Figure 3.4.** The lifecycle greenhouse gas (GHG) reduction benefit associated with using blue hydrogen (90% CCUS) to displace conventional fossil-fuel-based energy carriers. Details of calculations are provided in **Appendix A1**.



### 3.3. Blue Hydrogen and the Value of Managing Carbon

The greenhouse gas benefits of blue hydrogen production and use have significant economic implications for a new hydrogen energy system based on existing and emerging government programs. For example, the Alberta government's [Technology Innovation and Emission Reduction \(TIER\) program](#) has the potential to generate Emission Performance Credits (EPC) from the production of low carbon hydrogen, and the proposed [federal clean fuel standard](#) (CFS) could provide credits associated with a reduction in the lifecycle emissions associated with the traditional uses of liquid, solid or gaseous fuels (see **Box 3.1** for details). In addition, the CO<sub>2</sub> byproduct of blue hydrogen production could generate economic return if it is used for [enhanced oil recovery \(EOR\)](#).

While the EOR or the TIER-EPC benefits would ultimately accrue to the fuel producer, the CFS credit, if-and-when deployed, would depend on how the H<sub>2</sub> is used and would accrue to the company selling the H<sub>2</sub> as an alternative to a fossil fuel under the CFS regulation.

To assess the potential impact of these carbon values on the net cost of blue hydrogen as a fuel, two analyses were carried out.

- A. H<sub>2</sub> as a thermo-chemical fuel** - The first considers the cost of producing, compressing and pipelining hydrogen to nearby markets where it is used as a thermochemical fuel or industrial feedstock. Assuming a 400 t H<sub>2</sub>/day blue hydrogen production facility at a natural gas price of \$2/GJ, the H<sub>2</sub> production cost today would be about \$1.52/kg (**Figure 2.4A**). Added to that would be compression costs of about \$0.20/kg and pipelining costs to nearby markets of about \$0.60/kg.

#### **Box 3.1. Putting Value on Carbon Dioxide**

Programs that put a cost on CO<sub>2</sub> to encourage actions that prevent its release to the atmosphere have been implemented provincially and federally. Two of these programs include:

[Technology Innovation and Emission Reduction \(TIER\) program](#): sets benchmark emission standards for Alberta with increasing annual stringency. Compliance flexibility is provided with a carbon price of \$30/t CO<sub>2</sub>e in 2020, and \$40/t CO<sub>2</sub>e in 2021. Consistent with the federal [Greenhouse Gas Pollution Pricing Act](#), our analysis assumes a price of \$50/t CO<sub>2</sub>e in 2022 and beyond, even though this is not Alberta policy.

[Clean Fuel Standard](#): In British Columbia, a low carbon fuel standard requires liquid and gaseous fuels to meet lifecycle emission reductions targets. This program is [currently generating credits that sell for over \\$300/t CO<sub>2</sub>e](#). A similar federal regulation is now under development and beginning in 2022, with the objective of achieving a 30Mt reduction in GHG emissions by 2030. Credits can be earned with the supply of low carbon intensity fuels, actions in projects that reduce life cycle emissions, and end-use fuel switching. These credits can then be traded and sold.



### 3.3. Blue Hydrogen and the Value of Managing Carbon (Continued)

The resulting cost of delivered H<sub>2</sub> at reasonable scale (say 5 t H<sub>2</sub>/day) before considering the economic benefits of managing carbon would be about \$2.32/kg H<sub>2</sub>, equivalent to \$16.43/GJ<sub>h<sub>h</sub>v</sub>. **Figure 3.5** shows how this cost could be reduced with improvements in the capital and operating costs associated with carbon management in the blue hydrogen production, selling the byproduct CO<sub>2</sub> into markets such as enhanced oil recovery (EOR, **Figure 3.5A**), collecting Emission Performance Credits under the Alberta TIER program (TIER-EPC, **Figure 3.5B**) or generating credits under the federal clean fuel standard that is expected to be deployed in the next few years (CFS, **Figure 3.5C**).

Improvements in blue hydrogen technologies should reduce costs by \$0.31/kg H<sub>2</sub>, while EOR, TIER-EPC and CFS credits are projected to reduce the levelized cost of hydrogen (LCOH) by \$0.17, \$0.32 or \$0.96/kg H<sub>2</sub>, respectively. With today's technology, and the CFS credits (estimated as \$200/t CO<sub>2</sub>, based on [BC experience with this kind of fuel standard](#)), the net cost of H<sub>2</sub> should be about \$1.36/kg, equivalent to about \$9.62/GJ<sub>h<sub>h</sub>v</sub> H<sub>2</sub>. Compared with the price of natural gas in regions where blue hydrogen production is possible (typically \$1.50 to \$3.00 /GJ NG), zero-emission hydrogen is more expensive. However, cost reductions with large scale deployment of blue hydrogen and the potential to 'stack' some of the economic benefits of CO<sub>2</sub> management could further reduce the cost of blue hydrogen to \$1.05/kg H<sub>2</sub> (\$7.43/GJ<sub>h<sub>h</sub>v</sub>, **Figure 3.5C**) or lower. Perhaps most important from the perspective of the new clean fuel standard is that compared to other fuel changes (e.g. renewable natural gas), the use of blue or green hydrogen promises to be among the most cost effective.

- B. H<sub>2</sub> as a Transportation Fuel** - As a transportation fuel for fuel cell vehicles, hydrogen must be upgraded to fuel cell quality (i.e. high purity, lacking any contaminants that might damage the fuel cell) and compressed to 450 or 900 bars in order to be available, on demand, to vehicles coming to the fueling station. This significantly adds to the cost of the fuel, especially if low volumes are delivered each day. In our scenarios, focused on serving fleets of heavy trucks and buses, we assume larger fueling stations that deliver many tonnes of H<sub>2</sub>/day supplying both hydrogen fuel cell electric vehicles and H<sub>2</sub>-diesel dual fuel vehicles.

Few such stations of this size exist in the world today but [current estimates](#) place the cost at about \$2.20/kg H<sub>2</sub>. As these large fueling stations are deployed, the capital and operating costs are expected to decline 22% by 2030 and 43% by the time the technology deployment is mature (2040?). These costs are on top of the costs for hydrogen production, pipeline compression and distribution that would be shared with thermo-chemical demands using the same infrastructure (**Figure 3.5**). Therefore, the resulting cost for hydrogen as a transportation fuel would be about C\$4.52 assuming a 400 t/day facility is producing hydrogen when natural gas is \$2/GJ<sub>h<sub>h</sub>v</sub> (**Figure 2.4**), before considering the value of keeping the CO<sub>2</sub> from entering the atmosphere.



### 3.3. Blue Hydrogen and the Value of Managing Carbon (Continued)

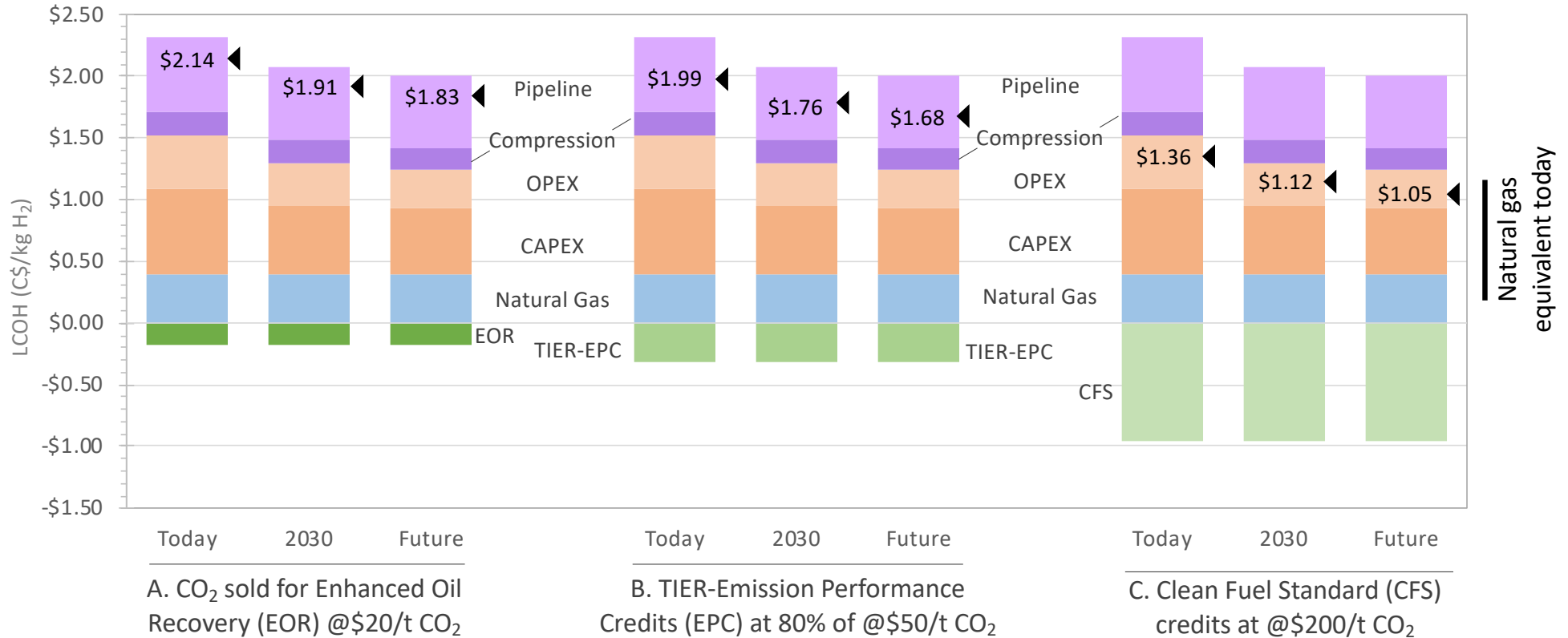

**Figure 3.5.** The effect of technology maturation (today, 2030 and future) and various values for byproduct CO<sub>2</sub> associated with the production, compression and pipeline distribution of blue hydrogen (assumes 400 t H<sub>2</sub>/day, \$2/GJh<sub>hv</sub> natural gas and 90% of CO<sub>2</sub> emissions captured and stored) for use as a thermo-chemical fuel. The values for CO<sub>2</sub> include it being sold for Enhanced Oil Recovery (A), it being used to generate emission performance credits (EPC) under the Alberta Technology Innovation and Emission Reduction (TIER) program (B), and potential credits generated under the clean fuel standard (CFS, assuming \$200/t CO<sub>2</sub>) (C). While shown separately here, some of these credits may be stackable. The cost associated with each triangle show the effect of the CFS on the net retail cost of hydrogen. The costs associated with each triangle show the effect of the carbon value on the net delivered cost of hydrogen.



### 3.3. Blue Hydrogen and the Value of Managing Carbon (Continued)

The carbon benefits from EOR or TIER-EPC discussed previously for hydrogen as a thermochemical fuel may also apply to hydrogen being used as a transportation fuel, but since it is not ensured that the benefits will be 'stackable,' only the clean fuel standard (CFS) benefits are shown in **Figure 3.6**.

Since the CFS benefits rely on lifecycle emission reductions, they depend on the technology used to displace an incumbent transportation fuel such as diesel. In a diesel vehicle modified to accept hydrogen as a dual fuel (40:60 H<sub>2</sub>:diesel by energy content), the calculated benefit is \$1.53/t H<sub>2</sub>, whereas a heavy duty HFCE vehicle should attract a carbon benefit of \$2.36/kg H<sub>2</sub> (**Figure 3.6**) since its more efficient drivetrain enhances the lifecycle benefits.

When the CFS credits are applied to the cost of hydrogen production and retail, the net retail cost (not including fuel taxes, but including a 8% return on capital investment) more than meets the target retail price of \$3.50 to \$5.00/kg H<sub>2</sub> as a transportation fuel. Some of this cost and price differential could be used to offset some of the additional cost associated with retrofitting or purchasing a H<sub>2</sub>-diesel or a HFCE vehicle compared to an incumbent diesel vehicle.

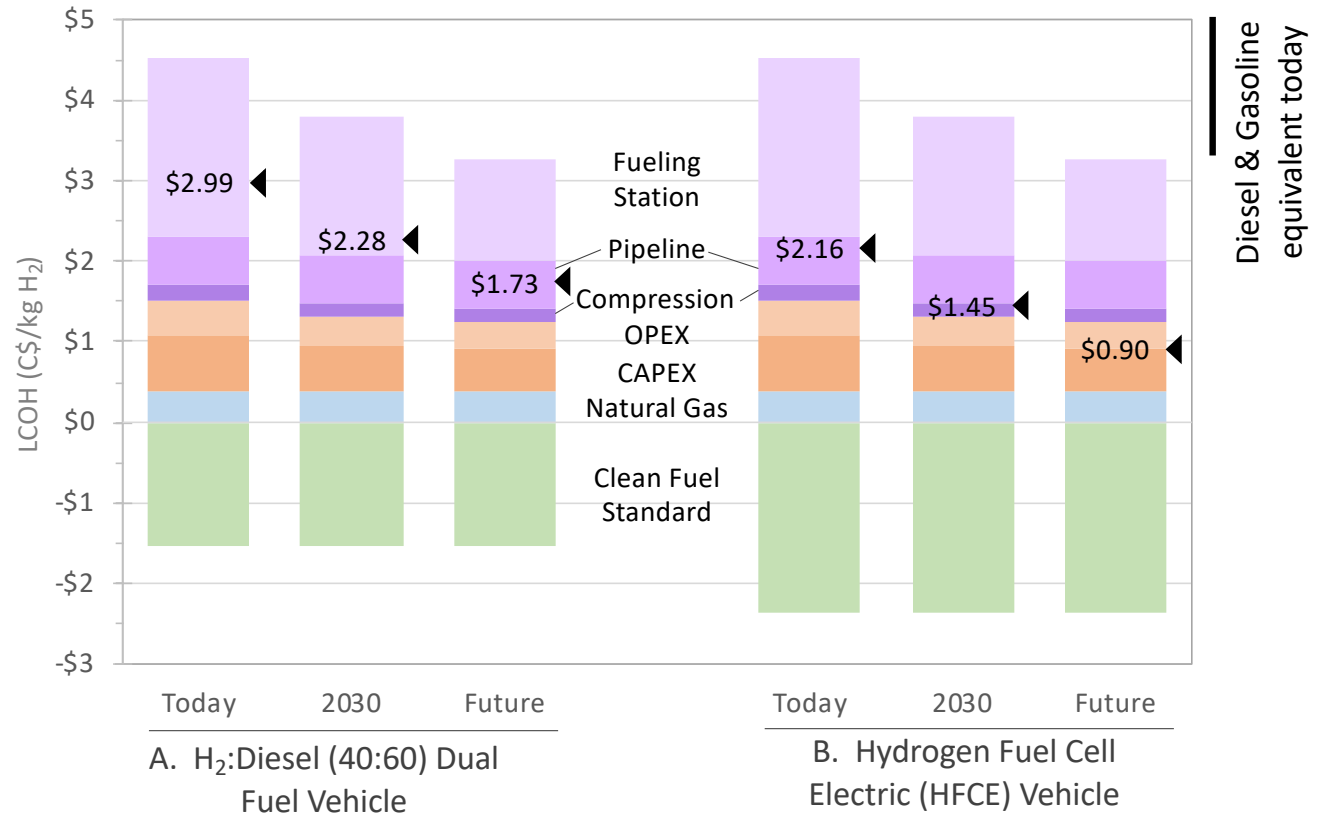

**Figure 3.6.** The effect of technology maturation (today, 2030 and future) and the clean fuel standard (assumes \$200/t CO<sub>2</sub>) associated with the production and use of blue hydrogen (assumes 400 t H<sub>2</sub>/day, \$2/GJh<sub>hv</sub> natural gas and 90% of CO<sub>2</sub> emissions captured and stored) as a transportation fuel to displace diesel use in heavy freight transport. The cost associated with each triangle shows the effect of the CFS on the net retail cost of hydrogen.



### 3.3. Blue Hydrogen and the Value of Managing Carbon (Continued)

It is worth noting that a H<sub>2</sub>-diesel vehicle does not require the high purity hydrogen need by a HFCE vehicle so theoretically, the fueling station costs could be lower for such vehicles. Moreover, the current premium required to create a H<sub>2</sub>-diesel vehicle compared to a diesel-only vehicle is, at about \$50K per vehicle, estimated to be about one fifth of the current incremental cost to build a HFCE heavy duty vehicle (about \$250K per vehicle) compared to the incumbent diesel vehicle. Therefore, an argument could be made that the focus should be on deployment of H<sub>2</sub>-diesel dual fuel vehicles as a means to facilitate the transition to a 100% hydrogen economy.

However, it is important to note that the H<sub>2</sub>-diesel vehicles are not capable of getting to net-zero, and the incremental cost of H<sub>2</sub>-diesel vehicles will always be more than diesel vehicles while HFCE vehicle prices are expected to decline as their scale of production increases and eventually a HFCE vehicle should be equal to or less than the diesel equivalent. The HFCE heavy duty vehicle is clearly the objective, and the H<sub>2</sub>-diesel vehicles can be part of the transition pathway in helping to build demand for H<sub>2</sub> at fueling stations. A more detailed technoeconomic, environmental and policy analysis is needed to identify the ideal deployment strategy for HFCE and H<sub>2</sub>-diesel technologies in the transition pathway to a net-zero energy future.



The Transition  
Accelerator



L'Accélérateur  
de transition

**TOWARDS NET-ZERO ENERGY SYSTEMS IN CANADA:  
*A KEY ROLE FOR HYDROGEN***

4. The Magnitude of the Opportunity



## 4.1. Potential Markets for Fuel Hydrogen in Canada

As discussed previously (**Section 1.1**), the transition to net-zero emission energy systems requires a restructuring of our current energy systems from the reliance on fossil-fuel based energy carriers (gasoline, diesel, natural gas, jet fuels) to zero-emission energy carriers like hydrogen and electricity. Moreover, the electricity or hydrogen must be produced with minimal or no greenhouse gas emissions. If fossil carbon-based fuels are used and GHG emissions result, those emissions will need to be offset by negative emission technologies such as biosphere carbon management or air capture coupled to carbon capture and storage.

In Canada, 541 (74%) of the 729 Mt CO<sub>2</sub>e/yr total GHG emissions are associated with the combustion of fossil fuels and 65% (349 MT CO<sub>2</sub>e/yr) of those combustion emissions are linked to end-use fuel combustion for transportation, buildings and the non-energy industry sectors (**Figure 4.1A**). These end-use energy sectors consume about 9.1 EJ<sub>h<sub>h</sub>v</sub> per year through energy carriers that include natural gas, gasoline, diesel, jet fuel, biomass and electricity (**Figure 4.1B**).

Assuming that end use combustion of fossil-fuel base energy carriers will not be economically viable in a net-zero emission energy future we calculated a 2050 energy mix (**Figure 4.1C**) that assumes:

- Efficiency and conservation measures offset population and economic growth over the next 30 years so the total end use energy demand in 2050 is the same as today, despite Canada serving another 8 to 10 million people;
- Electrification of end-use energy demand will be done where it is economically and logistically feasible and all electricity will be generated with very low (under 100 kg CO<sub>2</sub>e/MWh) generation sources;
- End use demand where electrification is not compelling or unlikely to be competitive relies on hydrogen or biomass as a fuel and/or energy carrier. For example, future hydrogen markets include 80% of current diesel markets (freight, trains, shipping), 30% of gasoline markets (fleet vehicles), 50% of heavy industry markets currently served by coal or natural gas, and 50% or more of the space heating market currently served by natural gas.

This analysis identifies a pan-Canadian end use hydrogen market equivalent to 27% of the primary energy needs of Canada, or ~3,300 PJ<sub>h<sub>h</sub>v</sub>/year. That would require 64 kt H<sub>2</sub>/day, or about 8 times the current H<sub>2</sub> production across Canada (**Figure 1.2**). At \$2/kg H<sub>2</sub> (\$14.16/GJ) in a pipeline, the potential contribution to the GDP is about \$47B/yr (**Figure 4.1**).

# 4.1. Potential Markets for Fuel Hydrogen in Canada

## A. Canada's Combustion Emissions

(541 Mt CO<sub>2</sub>/yr in 2018)

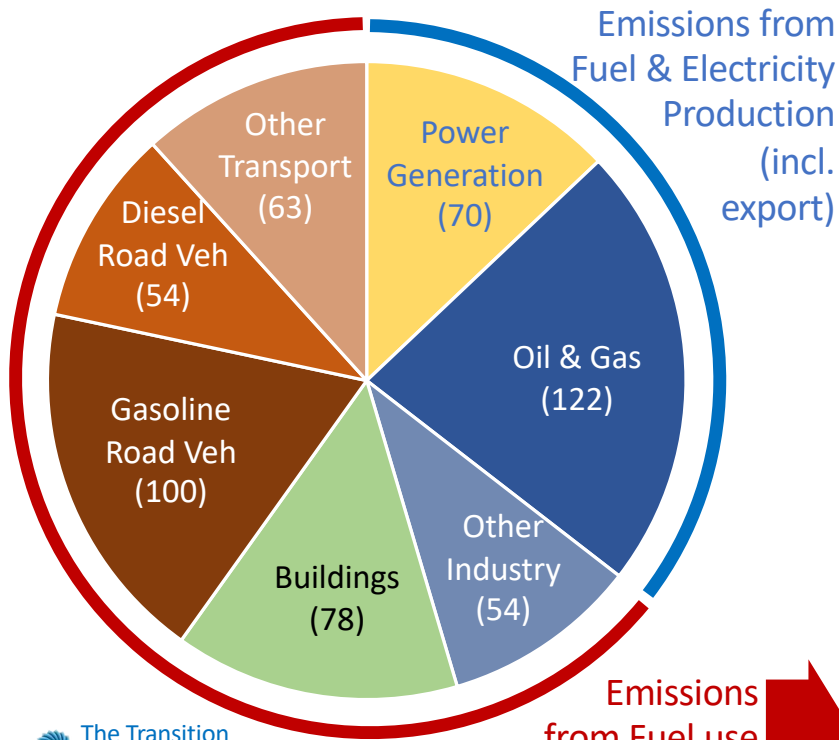

The Transition Accelerator

Emissions from Fuel use (9100 PJ/yr)

## B. Energy Carriers in 2017

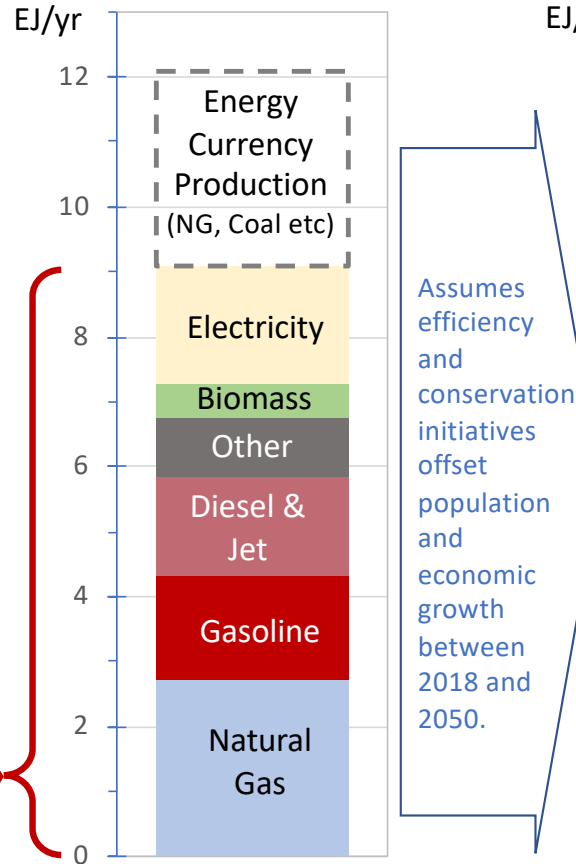

Assumes efficiency and conservation initiatives offset population and economic growth between 2018 and 2050.

## C. Energy Carriers in 2050

(one scenario model)

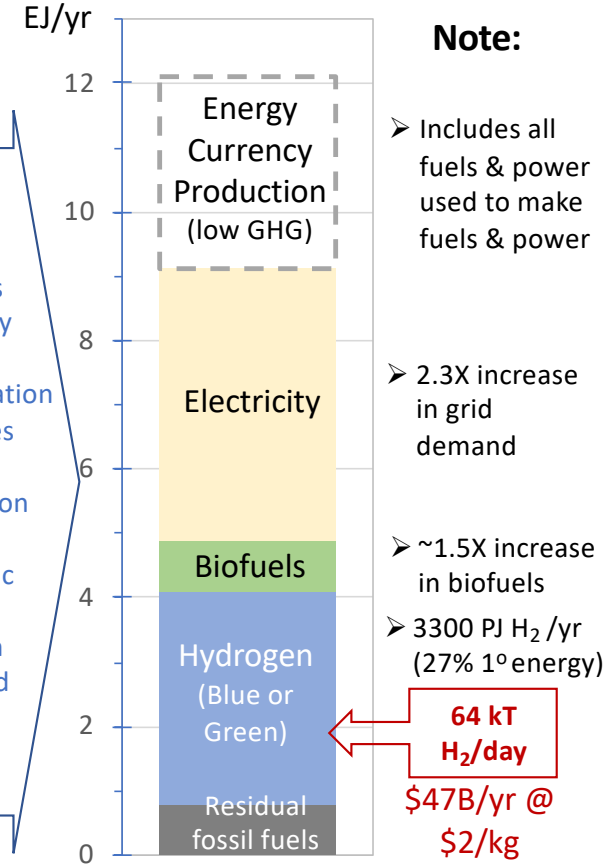

**Note:**  
 ➤ Includes all fuels & power used to make fuels & power

➤ 2.3X increase in grid demand

➤ ~1.5X increase in biofuels

➤ 3300 PJ H<sub>2</sub>/yr (27% 1<sup>o</sup> energy)

64 kT H<sub>2</sub>/day  
 \$47B/yr @ \$2/kg

**Figure 4.1.** A scenario projection for the potential market for fuel hydrogen and low or zero carbon electricity in Canada in a net-zero emission energy system in 2050. Panel A from the [National Inventory Report 2020](#). Panel 2 from the [NRCan comprehensive energy database](#).



## 4.1. Potential Markets for Fuel Hydrogen in Canada (Continued)

The 64 Kt H<sub>2</sub>/day needed to meet the projected future demand for the energy carrier (**Figure 4.1C**) could be produced from either low-carbon electricity or from natural gas (or other carbon-based fuels) coupled to carbon capture and storage (CCS) (**Figure 4.2**).

As discussed previously for green hydrogen (see **Figure 2.2C**), a future high-efficiency (87% HHV basis), low CAPEX electrolyzer would require 1054 TWh/year of zero or very low carbon electricity (**Figure 4.2**) dedicated solely to the production of hydrogen. This is equivalent to about 1.8 times the electricity distributed on the public grids of Canada in 2018. The scale of new generation capacity needed to provide this electricity (**Figure 4.2**) would be equivalent to about:

- 66,000 4.8 MW wind turbines operating at 38% capacity factor, or
- 30 nuclear power stations equivalent to Ontario's Bruce Station (4,700 MW) operating at 85% capacity factor, or
- 195 large hydro facilities equivalent to BC's Site C (1,100 MW) operating at 56% capacity factor.

As noted in **Figure 4.2**, this electricity demand would be in addition to about 700 TWh/year of new generation that would be required to serve the new direct power use in a 2050 energy system (**Figure 4.1C**).

If the 64 kt H<sub>2</sub>/year were to be provided as blue hydrogen from natural gas, the natural gas demand would be about 4,490 PJ /year, equivalent to about 72% of the total natural gas production in Canada in 2018 (**Figure 4.2**). Meeting this domestic demand for hydrogen would require a mixture of both 'blue' and 'green' hydrogen, but the current economics of production (**Figure 2.2** and **2.4**) and resource availability suggest that initially there would be more 'blue' than 'green' hydrogen. Eventually as primary energy resource or CCS storage space becomes limiting and renewable power generation has an increasing share in the public grids across Canada, 'green' hydrogen is expected to take a larger role.

Moving the hydrogen from sites of production to sites of utilization is a major challenge for this zero-emission fuel. While hydrogen can be trucked as a compressed gas or as a cryogenic liquid (LH<sub>2</sub>, -253C), both alternatives are expensive. In the case of compressed gas, tube trucks can only hold up to about 800 kg H<sub>2</sub> per load so transport adds significantly to the cost. In the case of LH<sub>2</sub>, many tonnes of fuel can be carried per truck load but liquefaction adds significantly to the cost, and if low carbon power is not available, it adds significantly to the GHG footprint. Ideally the scale of demand would justify the use of hydrogen pipelines to connect supply to demand. In Europe, a [hydrogen backbone](#) has been proposed, and a similar infrastructure needs to be considered for Canada.

## 4.1. Potential Markets for Fuel Hydrogen in Canada (Continued)

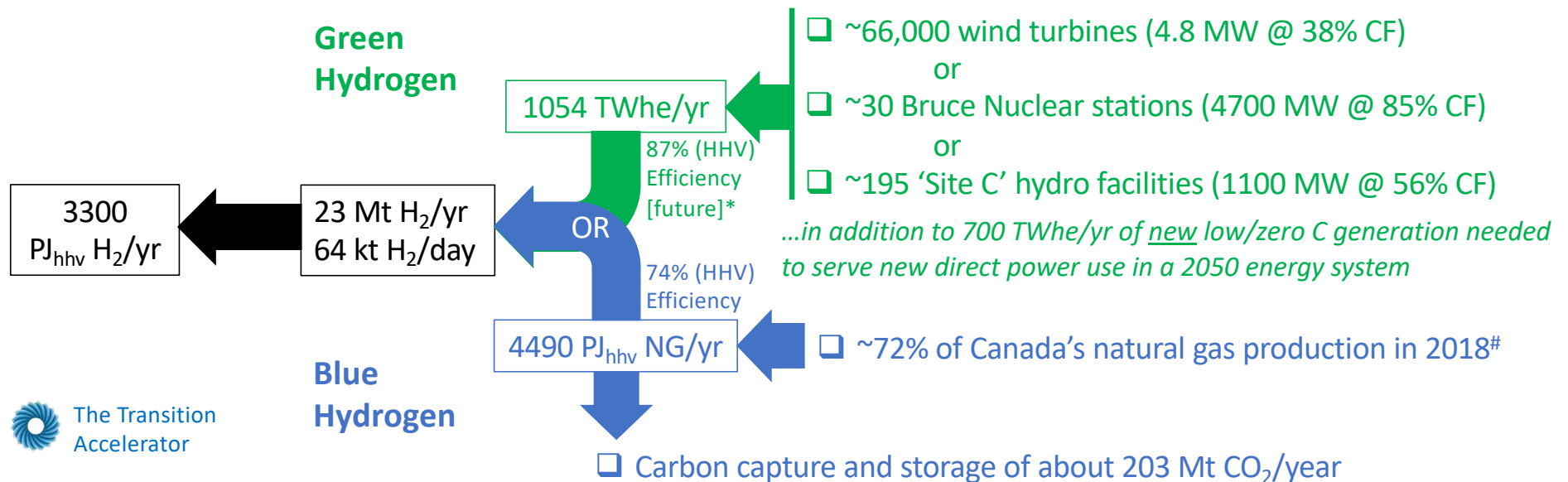

**Figure 4.2.** A summary of the strategies that Canada could use to provide 64 kt H<sub>2</sub>/day from very low or zero emission energy resources. For the green hydrogen alternatives, an 87% (electricity to HHV H<sub>2</sub>) conversion efficiency is assumed, reflecting the projected future technological advances in water electrolysis (see **Figure 2.2C**). \*, future electrolysis efficiency projected by IEA Future of Hydrogen (2017) report; #, 16.2 Bcf natural gas/day from [Canadian Energy Regulator](#).



## 4.2. Potential US Market for Canadian Fuel Hydrogen

If Canada is to transition to a net-zero energy system, it will be critical that the U.S., Canada’s major trading partner, simultaneously transitions. Assuming this occurs, the current U.S. demand for Canadian crude oil and natural gas will decline as end use demand shifts to low-carbon electricity or hydrogen.

Given that Canada currently sends about 5,300 PJ/yr of crude oil to the U.S. (**Figure 4.3A**, left bar chart) that refineries convert into about 3,500 PJ/year of transportation fuels (gasoline, diesel jet fuel), the demand for these carbon-based fuels is expected to decrease as electricity, biofuels and hydrogen take market share in a net-zero energy future.

In our scenario analyses, we assumed hydrogen would take market share by 2050 equivalent to 80% of today’s diesel market, 30% of the gasoline market and 10% of the jet fuel market. Taking into account the improved drivetrain efficiency of HFCE vehicles (**Figure 3.2**), the potential U.S. export market for hydrogen would be about 31 kt H<sub>2</sub>/day (**Figure 4.3A**).

To put that number into perspective, California’s recent [zero emission vehicle policy for heavy duty vehicles \(HDV\)](#) targets 40% of heavy duty vehicles to be zero emission (i.e. electric or hydrogen electric, post 2030). Assuming that 80% of those class 8 vehicles are HFCE by 2050, that would create a market demand for California alone of 10 kt H<sub>2</sub>/d.

In 2018, Canada also exported about 1,373 PJ/yr of natural gas to the U.S. If this market demand shifted to hydrogen, there would be demand for an additional 26 kt H<sub>2</sub>/yr. It is worth noting that [California has recently announce policies to phase out natural gas demand](#) in the state over the next 20 years. Currently, a natural gas pipeline carries Alberta natural gas to California. It may be worth exploring the feasibility of converting that pipeline to hydrogen so it can export blue and/or green hydrogen to the state. The retail price in [California for fuel cell grade hydrogen is US\\$13 to US\\$17/kg H<sub>2</sub>](#), and Alberta should be able to deliver hydrogen to the state at US\$3-4/kg H<sub>2</sub> or even less.

**Table 4.1.** Summary of potential North American market for blue and/or green hydrogen from Canada

Potential NA Markets	Market for H <sub>2</sub>	H <sub>2</sub> Price	Market
	kt H <sub>2</sub> /day	\$/kg H <sub>2</sub>	\$B/yr
Domestic	63.8	\$ 2.00	\$ 46.57
USA (oil alt.)	31.0	\$ 2.00	\$ 22.60
USA (gas alt.)	26.5	\$ 2.00	\$ 19.35
<b>Total</b>	<b>121.3</b>		<b>\$ 88.50</b>

## 4.2. Potential US Market for Canadian Fuel Hydrogen

### A. Potential Market Now Served by Canadian Crude

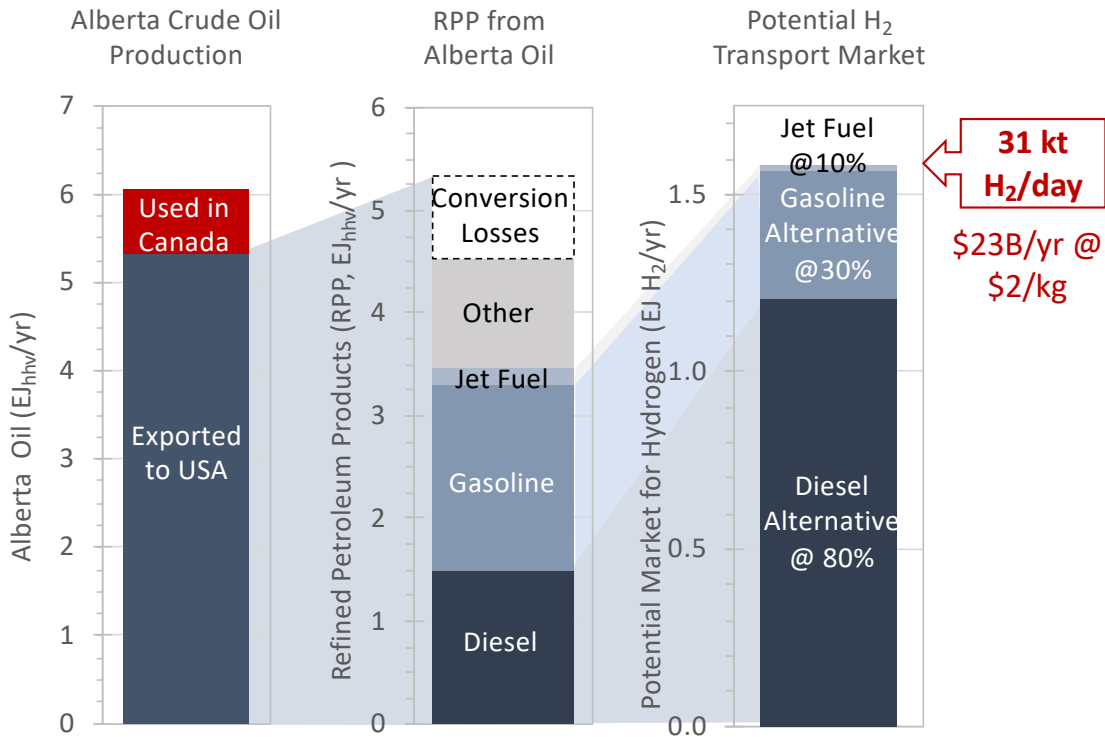

### B. Potential Market Now Served by Canadian Gas

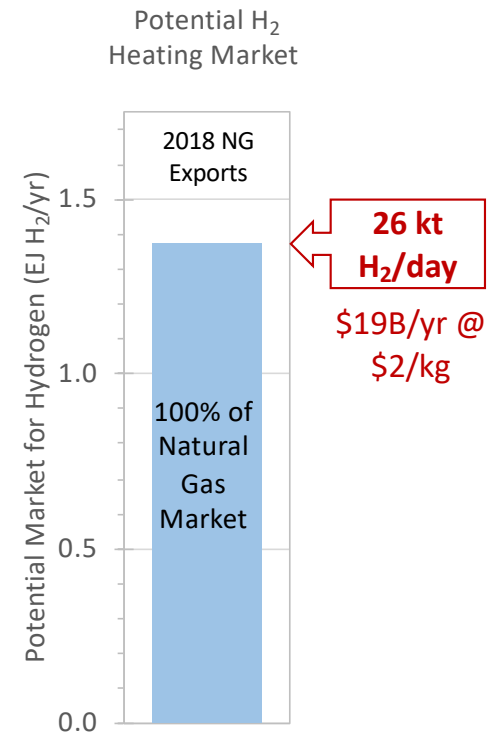

**Figure 4.3.** Calculation of hydrogen export potential associated with shifting to hydrogen, current U.S. markets for either Canadian crude oil (A) or Canadian natural gas (B).



## 4.2. Potential US Market for Canadian Fuel Hydrogen (Continued)

**Table 4.1** compiles the hydrogen market estimates from **Figure 4.1C** and **Figure 4.3 and 4.3B** to show a potential North American market for 121 kt H<sub>2</sub>/day, with 80% of the diesel, 30% of the gasoline, 10% of the jet fuel, and 50% to 100% of the natural gas market converted to hydrogen. This represents a transportation market of C\$22.6 billion/yr in the United States; given a \$2/kg price of hydrogen. The natural gas market to the U.S. is estimated to be a C\$19.35 billion/yr opportunity. Combined with a domestic value of C\$46.57 billion/yr, the magnitude of the North American hydrogen market is C\$88.5 billion/yr, all likely supplied by pipelines.



## 4.3. Potential Overseas Market for Canadian Fuel Hydrogen

There is also a growing overseas market for hydrogen as countries have rolled out their hydrogen strategies. This hydrogen would need to be converted into a cryogenic liquid (LH<sub>2</sub>) or into ammonia and put on a ship for overseas transport. For example, over the past year:

- [Japan](#) announced it aims to establish commercial supply chains that will procure 300 kt H<sub>2</sub>/yr (822 t H<sub>2</sub>/day) by 2030
- [South Korea](#) has projected a national demand of 5.26 Mt H<sub>2</sub>/yr (14.4 kt H<sub>2</sub>/day) by 2040
- [Germany](#) recently announced a national demand for about 2.5 Mt H<sub>2</sub>/yr (7.0 kt H<sub>2</sub>/day) by 2030.

These countries have limited domestic ability to produce hydrogen so they will be looking to import the zero-emission fuel from other nations. Assuming Canada attracts 50% of the potential market and the LH<sub>2</sub> sells for \$3.50/kg (a conservative price), the 11.1 kt H<sub>2</sub>/d market would contribute C\$14.20 billion to the Canadian economy (**Table 4.2**).

**Table 4.2.** Summary of potential Overseas market for blue and/or green hydrogen from Canada

Country with H <sub>2</sub> Import Plan	Market for LH <sub>2</sub>		Liquid H <sub>2</sub> Price	Market
	Kt LH <sub>2</sub> /day	% Mkt Share	\$/kg LH <sub>2</sub>	\$B/yr
Japan (2030)	0.822	50%	\$ 3.50	\$ 0.53
South Korea (2040)	14.4	50%	\$ 3.50	\$ 9.20
Germany (2030)	7.0	50%	\$ 3.50	\$ 4.47
<b>Total</b>	<b>22.2</b>			<b>\$ 14.20</b>



The Transition  
Accelerator



L'Accélérateur  
de transition

**TOWARDS NET-ZERO ENERGY SYSTEMS IN CANADA:  
*A KEY ROLE FOR HYDROGEN***

5. Summary and Conclusions



## 5.1. Summary of Findings

As Canada joins 72 other countries in committing to achieve net-zero emissions by 2050, most of the fossil carbon-based energy carriers – like gasoline, diesel fuel, jet fuel and natural gas – that currently provide over 70% of secondary energy demand in Canada will need to be replaced with zero-emission energy carriers like electricity, biofuels<sup>1</sup> or hydrogen (**Figure 1.1**). Moreover, these energy carriers must be produced with little or no greenhouse gas (GHG) emissions.

Canada is blessed with many options for the production of low-carbon electricity, including hydro, nuclear, wind, solar and fossil fuel generation coupled to carbon capture and geological storage.

However, hydrogen is also needed (see **Box 5.1**) and it can be produced from the electrolysis of water using low or zero-emission electricity ('green' H<sub>2</sub>), or from carbon-based feedstocks where the CO<sub>2</sub> byproduct is captured and geologically sequestered to prevent it from entering the atmosphere ('blue H<sub>2</sub>)<sup>2</sup>.

Most of the hydrogen production in Canada today (8.2 kt H<sub>2</sub>/day) is made from natural gas and the byproduct CO<sub>2</sub> is released to the atmosphere as a greenhouse gas (GHG) emission. That hydrogen is used as an industrial feedstock to make fertilizer nitrogen, crack bitumen to synthetic crude oil, and refine oil to fuels and chemicals.

<sup>1</sup> The production and use of biofuels produced without depleting biosphere carbon stocks are considered to have no GHG emissions. With Canada's vast biological resources, they can play an important role in Canada's energy future, but limited due to concerns about impacts on biodiversity, food vs. fuel production and energy costs.

<sup>2</sup> Hydrogen is also produced as a byproduct of some chemical processes (e.g. [Chlor-alkalal production of sodium hydroxide](#)), so that H<sub>2</sub> could be diverted for use as a fuel.

### BOX 5.1.

#### Why Hydrogen is Needed

Electricity is an excellent energy carrier that produces no emissions when it is consumed. Why is hydrogen also needed?

1. Some sectors need chemical, not electrical energy carriers, such as:
  - Freight transport, especially heavy duty, long distance and off road;
  - Fleet vehicles, especially large fleets that are heavily used and refueling logistics are
  - Heavy industries such as steel, cement, chemicals;
  - Space Heating, especially in cold regions, where heat pumps perform poorly.
2. Hydrogen complements low carbon electricity generation
  - Hydro, nuclear, wind & solar: when supply exceeds demand, the electricity can make hydrogen;
  - Hydrogen is an excellent electricity storage medium, especially for long term (days to seasonal) (see [Ref](#))
3. Hydrogen complements biofuel production
  - Increases conversion efficiency of biocarbon in production of bio-based diesel, jet fuel, natural gas etc.
4. More resilient, interconnected energy system
  - With hydrogen, a more resilient energy system is possible, moving away from today's three energy systems (transport, electricity, thermo-chemical)



## 5.1. Summary of Findings (continued)

In a net-zero energy future, any hydrogen made from fossil fuel carbon would need the byproduct carbon emissions captured and prevented from entering the atmosphere. The resulting blue hydrogen could be used either as an industrial feedstock or as an end use fuel.

Canada is [internationally renowned as a low-cost producer](#) of green hydrogen as a result of inexpensive, low-carbon electricity from hydro, nuclear, wind and solar resources, and of blue hydrogen due to its low-cost natural gas and ample CO<sub>2</sub> storage capacity, especially in the [Western Canadian Sedimentary Basin](#). The technoeconomic analysis carried out in this study shows that blue hydrogen can be produced in Canada today at about one half the wholesale cost of diesel fuel (per gigajoule of energy), while green hydrogen can be produced at a similar cost to diesel. If the production, distribution and retail of the hydrogen is done at an appropriate scale (i.e. similar to that currently used for diesel) and along strategic corridors linking supply to demand, it should be possible to provide hydrogen as a transportation fuel at a retail price that is competitive with diesel.

If the value-added benefits of managing the CO<sub>2</sub> associated with hydrogen production, including the existing carbon tax/credit initiatives like [Alberta's Technology Innovation and Emission Reduction \(TIER\)](#) program, and the new federal [clean fuel standard](#), the net cost of the hydrogen should be competitively priced as a low carbon alternative to natural gas for space heating and significantly lower than the current price of diesel as a fuel in support of heavy transport. The lower fuel cost in the freight transport sector could be very useful to help offset the higher cost of the H<sub>2</sub> vehicles compared to the diesel alternative. Indeed, the more fuel used by a heavy duty H<sub>2</sub> vehicles, the lower the total cost of ownership for that vehicle. This reality highlights the need to build this new energy system with vehicles that use large amounts of fuel so they can benefit from the fuel price while creating the necessary demand.

Our analysis estimated that green and blue hydrogen (plus some byproduct hydrogen) generated across Canada could fuel about 3,300 PJ/year of Canada's end use energy needs. The required 64 kt H<sub>2</sub>/day would make a C\$47B/year contribution to the Canadian economy assuming a C\$2/kg H<sub>2</sub> price on the H<sub>2</sub>. Export opportunities to the U.S. (via pipelining of 57kt H<sub>2</sub>/day) could add another \$42B/yr to the Canadian economy, and overseas shipping of liquid hydrogen (11 kt/day @ C\$3.50/kg H<sub>2</sub>) could provide another C\$14B/yr, for a total market potential of about C\$100B/year.



## 5.2. Hydrogen Nodes: on the Transition Pathway to a Net-Zero Energy System

A significant challenge in the transition to net-zero emission energy systems is the need to simultaneously build the supply and demand for the fuel, along with the systems to efficiently connect the two.

Currently hydrogen systems are caught in a self-reinforcing ‘vicious’ cycle where the cost of vehicles and other end-use technologies are high because there aren’t enough vehicles being made to support the cost of production. So with few vehicles or other end use technologies around to use the fuel, there is little demand for hydrogen and the costs for the fuel and the infrastructure to store and deliver it is very high. Of course, that adversely impacts the demand for the vehicles or other end use technologies and the vicious cycle repeats itself.

This challenge requires a coordinated effort to create an economically-viable ‘virtuous’ cycle that is not dependent on continuous government subsidies. The most important starting point is to identify reliable sources of low-cost, low GHG hydrogen. This could be a byproduct of an existing chemical facility, taking into consideration [the GHG footprint associated with diverting the hydrogen to other uses](#). It could also be a company or region that has excess low cost, low-carbon electricity and the desire to produce green hydrogen. Alternatively, it could be a company making hydrogen as an industrial feedstock that wants to produce low-carbon blue hydrogen and is willing to make some of that hydrogen available to a fuel market.

Once the hydrogen source has been identified, there is a need to identify substantial (from a minimum of 1-2 tH<sub>2</sub>/day, but potential to grow quickly to many 10’s to 100’s of tonnes H<sub>2</sub> per day) nearby concentrated centres of hydrogen demand, in sectors that could include transportation, space and water heating, steel making, or power generation, etc. There also needs to be a cost-effective, scalable strategy to connect supply to demand (eventually via pipelines, but perhaps not initially). Finally, there needs to be engaged industry, government and academic partners to fully develop the shared vision and bring it to life.

Although this ‘Hydrogen Node’ approach focuses on sub-regional scales, it can also support provincial or national hydrogen strategies. Ideally, two or more nodes will coordinate their activities to create, for example, hydrogen corridors to support long distance freight movement by roads or rail, or to help justify the building out of pipeline infrastructure that will serve communities between the nodes. The outcome of this approach will be an accelerated, strategic deployment of public-private partnerships along the value chain that connect low-cost, low-carbon hydrogen supply with new reliable markets for hydrogen as a fuel or industrial feedstock, using existing technology, and achieving the scale required for economic viability.



## 5.2. Hydrogen Nodes: on the Transition Pathway to a Net-Zero Energy System (continued)

Canada has the natural and human resources to make this transition occur before we are superseded by other nations already embarking on this transition.

If Canada is to meet its commitment to achieve net-zero emissions by 2050 and take advantage of the opportunity to not only meet our own energy needs but provide zero-emission energy carriers to other nations, action must be taken to integrate hydrogen into the net-zero energy system of the future. This endeavor, that has substantial economic and environmental benefits and has the potential to vault Canada into a global leadership position, will require that deliberate, coordinated efforts are made across sectors, jurisdictions, and other stakeholder groups.

**For further information, contact:**

Dr. David B. Layzell,

Tel: 403 220-5161

Email: [dlayzell@ucalgary.ca](mailto:dlayzell@ucalgary.ca)

Web: [www.transitionaccelerator.ca](http://www.transitionaccelerator.ca)